

**CASITAS MUNICIPAL
WATER DISTRICT**



REQUEST FOR PROPOSAL

#IFB0000119

**FILTER MEDIA
REMOVAL & CLEANING
FILTER #6**

*Bids will be received at the office of the
Casitas Municipal Water District,
1055 Ventura Avenue, Oak View, California 93022
until **Wednesday March 21st, 2018 @ 2:00 p.m.***

CASITAS MUNICIPAL WATER DISTRICT REQUEST FOR PROPOSAL

Filter Media Removal and Cleaning (Filter #6) March, 1st, 2018

A. INTRODUCTION

The Casitas Municipal Water District is currently requesting proposals from competent and experienced firms in the area of pressure filter media removal and installation techniques for the purpose of inspection and media cleaning of pressure filter #5 at the Marion Walker Pressure Filtration Plant. It is Casitas' intent to receive proposals and cost statements that include all contractor services, including labor, materials, and equipment necessary to complete the work described in this request for proposal. The filtration plant is located at 1888 Casitas Vista Road, Ventura, California 93002.

All work shall be performed in accordance with State, Federal and local County laws and codes.

B. PROPOSAL SUBMITTAL

Proposals shall be submitted to Casitas Municipal Water District, 1055 North Ventura Avenue, Oak View, California 93022, ATTN: Michael Shields. Submittal packages shall be in a sealed envelope, marked "Filter Media Removal & Cleaning (IFB 0000119)" in the lower left hand corner of the envelope and include the following:

- One (1) original printed copy of your proposal.
- One (1) electronic copy of your proposal in PDF format on CD, flash drive, or other electronic media.

Proposals will be accepted until **March 21st, 2018, at 2:00P.M.** No proposals will be accepted after that time and date.

C. PRE-PROPOSAL JOB WALK

A pre-bid job walk of the work site is required; the location of the mandatory job walk is 1888 Casitas Vista Road, Ventura, CA. 93002. Prospective bidders shall contact Michael Shields via e-mail at mshields@casitaswater.com and schedule a site visit during the normal working hours (8:00a.m. – 4:30p.m. / Monday through Friday) The job walk must be scheduled at least two (2) working days prior to bid due date. Submittals from contractors that have not performed a job walk will not be accepted.

D. PROJECT AND SCOPE

Furnish all material, labor, and equipment required to remove, clean, store and reinstall pressure filter media. **The media shall be removed, cleaned and stored with equipment certified as safe for potable water or be otherwise approved by the District.** Internal inspection of the pressure vessel will be performed by District personnel during the storage phase of this project.

The following prints, pictures, and information are attached for reference:

- VESSEL INTERNAL ASSEMBLY (Horizontal Media Filter) – **ASY-9016-01-01**
- PICTURES - (Pressure Filter #6 & 28" Access Manway)

The scope of work for this project shall consist of the following elements:

1. Filter media shall be removed and reinstalled via the two 28" access manways located on the top of the pressure vessel. (see attached picture for reference)
2. Removal and installation of the **anthracite and fine garnet** filter media layers shall be performed hydraulically via the use of a (contractor provided) slurry eductor. Any potable water necessary for eductor operations will be supplied by Casitas via a hydrant (app. 80 psi) located at the worksite. In the event a booster pump is required, it shall be supplied by the contractor. An appropriate spill containment area shall be setup to receive any process water associated with the media slurry processing. The resulting process water will be discharged into the treatment plants existing reclaim system.
3. At the contractor's discretion, removal and installation of the coarse (**support**) **garnet** filter media layer shall be performed via the use an educator and/or industrial vacuum equipment.
4. Alternative methods for media removal and installation may be submitted by the contractor to the district for review and approval. Under no conditions, will the district approve any removal methods that permit media be to pass through a pump impeller. The District reserves the sole right to reject any alternative methods that are considered unacceptable.
5. The contractor shall remove the media in a manner that keeps the filter media differentiated. If the media becomes mixed as a result of the contractor's selected method of removal, the Contractor, at the Contractor's expense, shall separate the material. The Contractor shall remove the media in a way that will provide no more than 5% loss of the media. Replacement of any media in excess of 5% of the amount per media layer shall be at the contractor's own expense.

6. The filter media shall be stored on site in “semi bulk” bags having lifting loops and bottom discharge spout, weighing approximately 2,000-4,000 pounds each and shall be appropriately covered to prevent contamination. The maximum weight of each “semi bulk” bag shall not exceed 4,000 pounds.
7. Following the removal of the filter media, the district will perform an internal inspection of the pressure vessel. A fourteen (14) calendar day period (window) will be allowed for district personnel to inspect and perform any necessary repairs. In the event repairs are not required and/or the work is completed before the fourteen (14) day window ends, the contractor will be notified.
8. Upon completion of the media cleaning and the vessel internal inspection, the media will be re-installed by the contractor. Installation shall be in accordance with AWWA B100-0.1, except as modified herein. The coarse (support) garnet shall be placed first, followed by fine garnet and finally anthracite in graded layers that meet original specifications for each media type. Supplemental (new) media shall be added as necessary to ensure design depth of all media types. Prior to beginning the installation of each media layer, the contractor shall mark the final elevation of the respective media by a level line on the inside wall of the filter to ensure adequate depth and volume. The required specifications for media layer depths are found in the attached drawing:

VESSEL INTERNAL ASSEMBLY (HORIZONTAL MEDIA FILTER) – ASY-9016-01-01

9. The coarse (support) garnet shall be carefully placed to avoid any damage to the existing filter underdrain laterals and shall be deposited in a uniform manner across the entire filter bed. Placement of the coarse garnet shall be performed in a single lift of approximately 13” of media. A backwash and surface scrape shall be performed following the installation of the media. The final depth of the coarse garnet shall be thirteen (13) inches after all necessary washing and surface scraping has been completed; proper depth of the media shall be achieved by screeding the filter media to the chalk line present on the interior filter wall.
10. The fine garnet and anthracite layers shall be placed and leveled in a manner similar to section 9 above. The contractor’s workers shall not stand or walk directly upon the media, but upon clean, and disinfected boards or plywood that will support their weight without displacing or crushing the media. Placement of both the fine garnet and anthracite shall be performed in a series of two (2) “lifts” of approximately 9” of media. A backwash and surface scrape shall be performed by the contractor following each lift. The final depth of the fine garnet and anthracite media layers shall be eighteen (18) inches each after all necessary washing and surface scraping has been completed; proper depth of the media shall be achieved by screeding the filter media to the chalk line present on the interior filter wall.

11. In the event Casitas deems it necessary, proper depth of media layers shall be verified against a level water surface maintained at the appropriate elevation mark.
12. Thorough backwashing shall be completed after the installation of each media lift. Following each backwash, the surface of the filter media shall be cleaned (scraped) to remove all fines and foreign material that have accumulated. The District will operate all valves necessary to provide the backwashing. The contractor shall be responsible for all other actions including but not limited to securing the pressure vessel, cleaning the surface of the media, and reinstalling the filter media. The District requires a minimum two (2) hours' notice prior to each backwash in order to ensure adequate water availability and storage volume in the washwater reclaim system.
13. At completion of the filter media installation, the filter will be disinfected by Casitas staff in accordance with AWWA C653 standards.

E. SPECIAL CONDITIONS

1. Project Location/Access The treatment plant filters are located at the base of Casitas Dam in a secured area at the northern terminus of Casitas Vista Road. The contractor shall coordinate access into the secured area with the District. The contractor will be responsible for compliance with traffic speeds and safe driving.
2. Requirement. The work to be performed under the purchase order contract shall consist of furnishing all tools, materials, supplies and manufactured articles and for furnishing all transportation, services, including fuel, taxes, permits, and the performance of all labor, work or other operations required for the fulfillment of the contract. The work shall be complete, and work, materials and services not expressly called for in this Request for Proposal which may be necessary for the complete and proper workmanship to carry out the contract in good faith shall be performed, furnished and installed by the Bidder at no increased cost to the District.
3. Contractor All Contractors submitting proposals shall be licensed in the State of California in the appropriate disciplines for the scope of work and have a minimum of five (5) years' experience in performing similar projects. The Contractor shall evidence this requirement by furnishing a written list of references to include names and phone numbers with the Bidder's Questionnaire and submit the said list to the District with the proposal.
4. Prevailing Wage Rate. In accordance with the provisions of Section 1770 of the California Labor Code, the Casitas Municipal Water District has ascertained the

general prevailing rate of wages applicable to the work to be done. It shall be mandatory upon the Contractor to whom the contract is awarded, and upon the subcontractor under them, to pay not less than the specified rates to all laborers and mechanics employed by them in the execution of the contract. The wage scale can be viewed at http://www.dir.ca.gov/OPRL/statistics_research.html

The project is recognized as a public works project and as such Articles 1 and 2 of Chapter 1, Part 7, Division II of the California Labor Code, including Sections 1720 through 1861 are applicable to this project. Said sections require the use of prevailing wages for each craft or classification necessary to do the work. Contractors and Subcontractors shall be registered pursuant to this section to be qualified to bid on, be listed in a bid proposal, subject to the requirement of Section 4104 of the Public Contract Code or engage in the performance of any public work contract that is subject to the requirements of this chapter. For the purposes of this section, "contractor" includes a subcontractor as defined by Section 1722.1

All bidders and their subcontractors shall be registered with the California Department of Industrial Relations (DIR) in accordance with Labor Code Sections 1725.5, 1771, 1773.3 and 1776. Failure of the bidder or subcontractors to be registered with the DIR shall render their bid as non-responsive and will be rejected except where State code provides for exceptions to the registration requirements. All contractors and their subcontractors shall furnish electronic certified payroll records directly to the Labor Commissioner, also known as Division of Labor Standards Enforcement.

5. Pre-Construction. Prior to the start of project work, at a time agreed on between the Contractor and the District, a pre-construction and safety conference shall be held for the purpose of discussing and familiarizing all concerned parties with the contract documents, procedures, standards, access, correspondence, material requirements and safety issues relevant to this project. The pre-construction meeting will be held at the filtration plant located at 1888 Casitas Vista Rd, Ventura, CA. 93002. Personnel to be present at this meeting are representatives of Casitas, the General Contractor and his superintendent, the subcontractors and their foremen and/or superintendents.
6. Beginning and Completion of the Work.
 - (a) The Contractor shall begin the work within fourteen (15) calendar days after the issuance of the Purchase Order.
 - (b) The contractor shall have thirty five (35) calendar days to complete the required work, inclusive of the 14 day district inspection window. If additional working days are needed they may be negotiated based on the amount and type of work. All work should be performed in a way as to minimize the disruption to

the District's current operations, including, but not limited to working hours of 8:00 a.m. to 4:30 p.m. - Monday through Friday – and no work on such days as recognized state or federal holidays.

(c) Work completed after the contract time specified above will be subject to liquidated damages of \$500 per day beyond the calendar days provided for this work.

7. Security and Site Access.

(a) The access to the facility is strictly controlled by the District. The Contractor shall provide a written list of the names of all Contractors' employees that are to be considered by the District for access to the work site. The District will communicate any restriction or denial of access of any Contractor employee, as the District deems necessary.

(b) Work may only be performed between the hours of 8:00 AM and 4:30 PM Monday through Friday; work outside of these hours is prohibited unless District grants explicit written approval. Should the contractor's employees not be out of the secured site by 4:30p.m. each work day, the contractor shall have deducted from any amount that is due the contractor at a rate of \$140.00 per hour or part thereof until the employees are out of the secured area.

(c) The Contractor shall be responsible for the safe security and storage of the equipment and materials that are left at the job site. Further, the Contractor shall secure the site when not present.

(d) All work shall be performed in a way as to minimize the disruption to the District's current operations.

(e) The Contractor and their subcontractors shall not be allowed to live on site.

8. Work Area.

(a) The Contractor shall be limited to the work area in and around the project site, as delineated by the project and shall cooperate with District staff in keeping the access routes open and minimizing potential hazards.

(b) The Contractor shall be responsible for maintaining a clean work environment and shall be responsible for the removal and disposal of trash and excess materials resulting from the project.

(c) The Contractor shall also be responsible for any damage to district infrastructure done by them or their employees. In the event of the contractor's failure to do so, the repair work may be done by the District at the Contractor's expense.

9. Permits.

(a) Contractor's attention is directed to Section 30 of Part B - General Conditions of these specifications. Contractor is required to obtain all appropriate permits for work.

(b) In the event that the District or the Contractor is issued a notice of warning of noncompliance from any agency which issues a permit, it shall be the responsibility of the Contractor to immediately take whatever action is reasonably required to have said notice or warning lifted.

10. Power and Sanitation .The Contractor will be required to make his own arrangements for sanitation and power required during for the project. In the event water is obtained from existing District facilities, the water will be furnished free of charge, but the Contractor shall install and subsequently remove at his expense, all temporary facilities required to obtain and use the water. The Contractor shall provide and maintain sanitation facilities for his workers at the project site; at a minimum this shall be one regularly maintained portable toilet facility.

11. Safety. All work shall be performed in conformance with general industry safety orders of the State of California, Title 8 of Chapter 7, and safety standards set forth by the Occupational Safety and Health Agency (OSHA).

12. Underground Utilities. The Contractor shall protect all existing utilities in the project area. Contractor shall be responsible for contacting Underground Service Alert as required by state law. Contractor shall repair any damage to utilities caused by this project.

13. Coordination of Work.

(a) The Contractor shall coordinate his work with the District, material suppliers, manufacturers and subcontractors during the course of the work, per approval by the district.

(b) Casitas will provide direction and assistance in the safe shutdown, lock-out tag-out and block- out of the equipment at the facility.

14. 28" Filter Manway Gaskets The existing flange gaskets (quantity 2) and one additional set (quantity 2) of gaskets will be provided to the contractor for the project. Any additional gaskets required shall be provided by the contractor.

15. Supplemental Media. Supplemental media supplied by the contractor shall be material as normally supplied for use in water treatment plant filters, filtering settled and/or coagulated water in a potable water treatment plant and shall conform to the latest versions at time contract is awarded of AWWA Standard B100 and NSF Standard 61 – Drinking Water System Components

- Anthracite: The anthracite shall be composed of hard and durable grains, and shall be processed from anthracite coal. The origin of the anthracite must be the United States. Blending of non-anthracite material to meet any portion of this standard is not acceptable. The anthracite filter media shall have the following characteristics:
 - a) Effective size (mm 1.00 to 1.10)
 - b) Uniformity coefficient (less than 1.5)
- Fine Garnet: The fine garnet shall be composed of hard, durable, dense, and uncoated grains, of at least 85 percent siliceous material that will resist degradation during handling and use. The garnet sand filter media shall have the following characteristics:
 - a) Mesh size (30-40) / (mm .59 -.42)
 - b) Uniformity coefficient (less than 1.5)
- The contractor shall supply an affidavit of compliance to the district certifying that the supplemental filter material provided complies with the required specs and standards contained above (AWWA B100 / NSF 61 / Specified Size & Uniformity Coefficient)
- All filter media shall be shipped in "semi-bulk" bags having lifting loops and bottom discharge spout, weighing approximately 2,000-4,000 pounds each. All costs associated with transporting and delivering the media shall be borne by the contractor.

16. Materials. All parts and materials provided for construction of the project shall be new unless otherwise indicated.

17. Final Clean-up. Reference is made to Section 45 of Part B. Upon completion of the work and before final inspection and request for payment, the Contractor shall remove and dispose of all items used under his direction. A general cleanup shall be performed to the satisfaction of the District.

18. Contract.

(a) The contractor shall provide insurance in accordance with the District's General Conditions (Part B).

(b) Any review and discussion of the bills shall not be cause for extra cost or

billings.

(c) Any dispute shall be resolved in accordance with the District's General Conditions (Part B)

F. PROPOSAL CONTENT

It is the intent of this Request for Proposal to seek only those proposals that will directly address the particular project of Casitas Municipal Water District. The Contractors submitting proposals need not provide any general information about the firm, but only that particular information that specifically addresses the needs of this proposal. The scope provided by the proposal should address not only the details in the request for proposal, but should also address those issues and relative points that may not have been described in the Request For Proposal, which the Contractor believes to be pertinent to this particular project specified. The proposal should contain the following elements:

1. Experience. The proposal content should begin with the experience the firm has with projects similar to that proposed by Casitas. The Contractor should submit a listing of references of no less than 3 with names and phone numbers of each similar project the Contractor has performed in the past five (5) years. The Contractor shall also provide a listing of all subcontractors whose work has a monetary value of 15 percent or more of the total price bid and shall include their reference experience as required of the primary

2. Time Frame and Work Plan. The proposal must include a general work plan and time frame for the work to be completed. At a minimum this shall contain a description of the scope of work and how the firm intends to approach the project task and complete the scope of work in a timely manner. The Contractor shall provide a listing of those services to be provided during the course of the work and contribute to the cost element of the project.

3. Submittals. The Contractor shall submit the following info as a part of the proposal.

(a) Warranty information for materials and work to be provided by the contractor, including but not limited to the name and address of the responsible person(s) responsible for warranty work, conditions of the warranty, and period of time warranty will be valid.

(b) Any product which the contractor intends on using in the project, which is not described in the specifications or is believed to be an equal to the specified product.

4. Safety Plan. A copy of the contractor's safety plan shall be provided to Casitas prior to the start of work, and a copy of all contractor's training, incident reports, and safety permits shall be provided to Casitas as they are completed.

5. Lump Sum Fee. The proposal shall include the lump sum fee to complete the work. Any request for additional payments, without written approval by the District of a Change Order, will not be honored by the District. The firm shall identify any conflicts which they believe could affect the project work and the ability to complete on schedule.

6. Notification of Conflict. Contractor shall submit in writing to District if it identifies any conflicts which could affect the project and the ability to complete on schedule.

G. SELECTION

As determined by the District, the bid will be awarded to the lowest responsible and responsive bidder that contains a bid for the total amount to complete the specified work. The bid amount will be determined by the total for bid items. In the event the total bid amount exceeds the budgeted amount for this project, the District reserves the right to delete bid item(s) and the new cumulative total becomes the bid amount.

The selection of the Contractor to complete the work will be based upon the following criteria:

1. Qualifications and experience of the persons identified as being a major resource on the project.
2. Number of successfully completed pressure filters media removal/ cleaning jobs over the previous five year period.
3. The thoroughness, thought and detail put into the proposed work plan provided by the contractor.
4. Statement of ability to complete all work in the time given for the project.
5. The fee specified by the Contractor to complete the scope of work, and the quantity of work hours estimated to complete the work.
6. The proposed time required to complete the project.

If the District is unable to enter into agreement with the selected contractor for any reason, it reserves the right to award the contract to the next most qualified contractor who submitted a bid. The same selection process would be used to select the alternate contractor. The District reserves the right to retain all bids for a period of forty five (45) days and to reject any bids that are considered unacceptable or any bids for any reason at the sole discretion of the District, or to waive any minor irregularities for any reason with or without cause.

H. CONTRACT DOCUMENTS:

The contract documents shall consist of the following:

1. The Request for Proposal
2. The Contractor's Proposal (inclusive of bidding sheet, bidder's plan, and bidder's statement of subcontractors)
3. Casitas' Specification Part B – General Conditions
4. Drawings and Pictures (2 Pages)
5. Bonds are required for proposals over \$35,000

I. CONTRACT

It is expected that upon successful selection and approval of the proposal by Casitas, Casitas will issue a Purchase Order contract with the proposing firm for the project.

The conditions to be included in are as follows:

- (a) A "no attorney's fees" clause.
- (b) A "no interest" clause.
- (c) That Casitas be provided with and retain ownership of all documents, product manuals, files, or other work generated in connection with this project.
- (d) That the firm and any Subcontractor shall provide workmen's compensation insurance and liability 4 insurance as required.
- (e) That any review and discussion of the bills shall not be cause for extra cost or billings.
- (f) Any dispute resulting in lawsuits shall be filed and processed in Ventura County in accordance with the laws of the State of California.
- (g) The full and agreed upon project description as contained herein, or as revised, including Casitas' General Conditions (Part B) including insurance requirements.

J. PAYMENT

Casitas shall only accept one (1) payment request from the selected Contractor. Invoices shall contain a purchase order number and fully define the work components completed. No advance payment or deposit will be paid. Retention shall be held by the District, in accordance with the District's General Conditions attached hereto. Casitas reserves the right to require the firm to submit a certified payroll for all employees covered by prevailing wage requirements.

CASITAS CONTACT

Michael Shields
Treatment Plant Supervisor
1055 N. Ventura Avenue
Oak View, Ca 93022
mshields@casitaswater.com

**BIDDING SHEET
 FILTER MEDIA REMOVAL AND CLEANING (FILTER #6)**

Schedule of prices for all work, materials, labor and site cleanup for the above-mentioned project in accordance with this proposal. Any item not specifically mentioned shall be considered incidental to the item to which it pertains. The bidder shall list prices for all bid items. Bids received which do not list prices in succession may be rejected.

Bid Item #	Quantity & Unit	Description & Price in Words	Amount \$
1	LS	Remove, store, clean, and re-install the filter media for the lump sum of _____ Dollars	
2	81 CF	Provide and install supplemental garnet filter media (30-40 mesh) for a unit cost of _____ dollars per cubic foot	
3	180 CF	Provide and install supplemental anthracite filter media (1.0 – 1.1mm) for a unit cost of _____ dollars per cubic foot	

TOTAL BASE BID AMOUNT (Items 1-3) \$ _____

The above quantities are based on a lump sum or unit price; measurement and payment for each bid item per the specifications. Bidder will not be released on account of errors. When a discrepancy occurs between the written price and the number listed, the written price shall govern. Bid amounts will be determined by the total for base bid items 1-3. The Bidder understands that the District reserves the right to reject any or all bids and to waive any formalities in the bidding.

Date: _____ **BIDDER:** _____

By: _____

Title: _____ Telephone Number: _____

License # _____ Date License Expires: _____

DIR License # _____ Date License Expires: _____

(CORPORATE SEAL)

License Classifications: _____

Fax: _____ Email: _____

Address: _____

BIDDER'S STATEMENT OF SUBCONTRACTORS

The bidder is required to state the name and address of each subcontractor who will perform work in an amount in excess of one-half (2) of one percent (1%) of the total bid price and the portion of the work which each subcontractor will do.

The undersigned submits herewith a list of subcontractors whom they propose to employ on the work, with the proper firm name and business address of each and a statement of the work or bid item which will be done by each subcontractor.

Subcontractor	Portion of Work
Location and Place of Business	
License No.	Expiration Date: / / Phone ()

Subcontractor	Portion of Work
Location and Place of Business	
License No.	Expiration Date: / / Phone ()

Subcontractor	Portion of Work
Location and Place of Business	
License No.	Expiration Date: / / Phone ()

Subcontractor	Portion of Work
Location and Place of Business	
License No.	Expiration Date: / / Phone ()

Subcontractor	Portion of Work
Location and Place of Business	
License No.	Expiration Date: / / Phone ()

Signed:

BIDDER'S QUESTIONNAIRE

INSTRUCTIONS

Pending award of a contract to the lowest bidder, Casitas requires bidders to submit a statement of their technical ability and experience. Casitas reserves the right to require a statement of the lowest bidder's current financial condition (Part IV attached) prior to award of the contract.

Each bidder shall be required to complete the attached Bidder's Questionnaire with the exception of Part IV.

PART I - BIDDER'S STATEMENT OF TECHNICAL ABILITY AND EXPERIENCE

A. History of Bidder

1. Total years of organization doing business. _____

2. Has your organization done business under another name? Yes _____ No _____

If yes, state name and address of organization(s) and/or names and addresses of owners or principals.

_____	_____
_____	_____
_____	_____
_____	_____

3. List all principals, owners, partners and stockholders owning more than 10 percent of a corporation.

Name

Name

_____	_____
_____	_____
_____	_____
_____	_____

4. State the name of your organization's Responsible Managing Employee or Officer.

Name	State Contractor's License No.	Classification

Bidder's Questionnaire (Continued)

B. Experience

List all of the jobs in which your organization has been involved during the last five years where the predominant type of construction is similar to this job.

1. Project Completion Date⁽¹⁾ _____

Value of Contract⁽²⁾ _____

General Description of Work⁽³⁾ _____

Name and Address of Owner _____

Party to Contact _____

Phone Number _____

State whether organization was prime, joint venture, sub or other: _____

2. Project Completion Date _____

Value of Contract _____

General Description of Work _____

Name and Address of Owner _____

Party to Contact _____

Phone Number _____

State whether organization was prime, joint venture, sub or other: _____

- (1) Project Completion Date - If current, state current; if incomplete, state incomplete.
- (2) Value of Contract is the total amount of money paid for your work, including all settlements or judgements.
- (3) General Description of Work should indicate the predominant type of construction; i.e., water pipeline, paving, earthwork, and sewer, pump plant, etc.

Bidder's Questionnaire (Continued)

3. Date of Project _____
Value of Contract _____
General Description of Work _____
Name and Address of Owner _____

Party to Contact _____ Phone Number _____
State whether organization was prime, joint venture, sub or other: _____

4. Date of Project _____
Value of Contract _____
General Description of Work _____
Name and Address of Owner _____

Party to Contact _____ Phone Number _____
State whether organization was prime, joint venture, sub or other: _____

5. Date of Project _____
Value of Contract _____
General Description of Work _____
Name and Address of Owner _____

Party to Contact _____ Phone Number _____
State whether organization was prime, joint venture, sub or other: _____

PART III – CONTRACTOR’S SAFETY RECORD

1. List your firm’s experience modification rate (EMR) for the last 3 years. The EMR is available from your Worker’s Compensation Insurance firm. This is only required from Firms with Worker’s Compensation Insurance premiums in excess of \$50,000.

Year	EMR	Year	EMR	Year	EMR
------	-----	------	-----	------	-----

2. List your firm’s Recordable Incident Rate (RIR) for the last 3 years. Incident Rate information is available from your OSHA 200/300 Log and from your insurance carrier.

$$\frac{\text{Total number of recordable incidents} \times 200,000}{\text{Total employee hours worked}} = \text{RIR}$$

Year	RIR	Year	RIR	Year	RIR
------	-----	------	-----	------	-----

3. List your firm’s Lost Time Incident Rate (LTIR) for the last 3 years. Incident Rate information is available on your OSHA 200/300 Log and from your insurance carrier.

$$\frac{\text{Total number of lost time incidents} \times 200,000}{\text{Total employee hours worked}} = \text{LTIR}$$

Year	LTIR	Year	LTIR	Year	LTIR
------	------	------	------	------	------

Casitas has established the following requirements for this project:

EMR – None greater than 1.2 over the last 3 years

RIR - None greater than 9 over the last 3 years

LTIR – None greater than 4 .5 over the last 3 years

4. Do you have a written safety program that includes hazardous communications? YES / NO

5. Do you have a substance abuse policy? YES / NO

6. Do all new employees complete safety orientation before performing any work activities? YES / NO

7. Do you conduct jobsite safety inspections? YES / NO

8. Do you conduct and document post accident investigations? YES / NO

PART IV - FINANCIAL RESPONSIBILITY (To be Completed only if Requested by Casitas)

- 1. Submit your most recent audited financial statement or financial data or other information and references sufficiently comprehensive to permit an appraisal of your current financial condition.
- 2. Submit your most recent balance sheet and profit and loss statement.

I certify under penalty of perjury that the foregoing is true and correct.

Name of Organization

By: _____

Title: _____

Date: _____

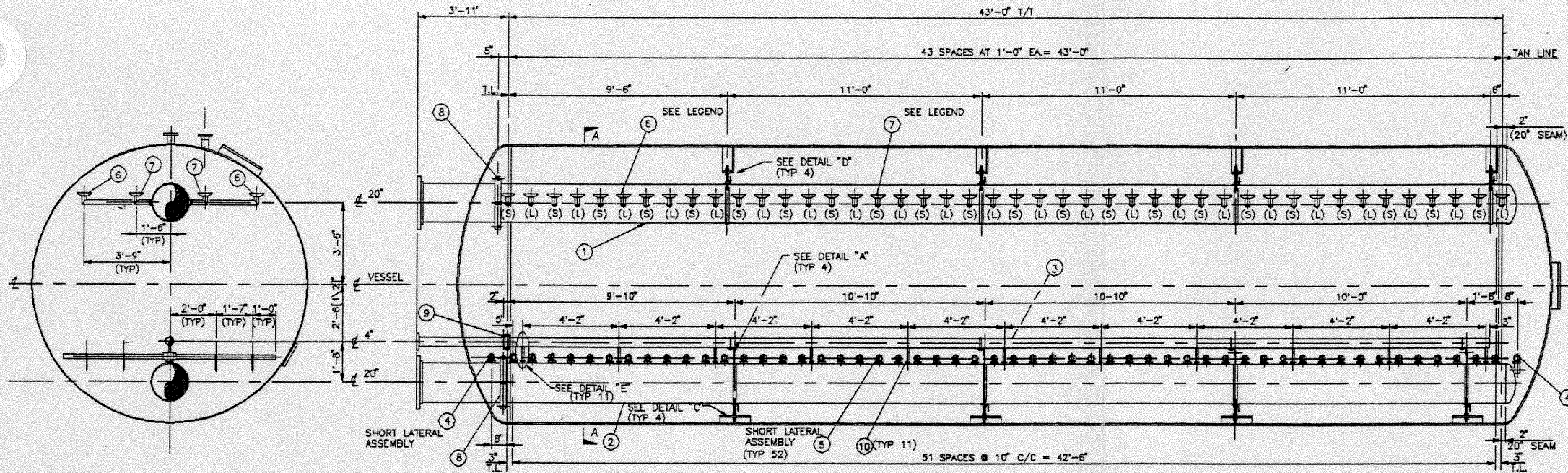

BILL OF MATERIALS		
ITEM	QUAN	DESCRIPTION
1	1	INLET HEADER
2	1	OUTLET HEADER
3	1	AIR SCOUR HEADER
4	4	SHORT LATERAL
5	104	LONG LATERAL
6	44	LONG DISTRIBUTOR
7	44	SHORT DISTRIBUTOR
8	2	20" VICTAULIC CPLG STYLE 77 W/TYP "F" GASKET 316 S.S.
9	1	4" VICTAULIC CPLG STYLE 75 W/TYP "E" GASKET 316 S.S.
10	11	1" VICTAULIC CPLG STYLE 77 W/TYP "E" GASKET 316 S.S.
11	4	20" OUTLET HEADER STRAP ASSY
12	4	20" INLET HEADER STRAP ASSY
13	8	INLET & OUTLET HEADER HORIZ. SUPT ANGLE
14	54	2"x2"x2(1/2)" BULL TEE (THRD) 316 S.S.
15		
16	218	2" CONCRETE ANCHOR STRAP ASSY
17	4	STANDARD U-BOLT 4" C/W NUTS & WASHERS S.S.
18	48	1" UNC HH NUT 316 S.S.
19	11	1" ORIFICE WASHER, 316 S.S.
20	48	1" FLATWASHER, NARROW PLAIN 316 S.S.
21	32	1" FLATWASHER, NARROW PLAIN, NYLON.
22	32	1" LOCKWASHER HELL SPR. 304 S.S.

SECTION "A-A"
SCALE: 3/8"=1'-0"

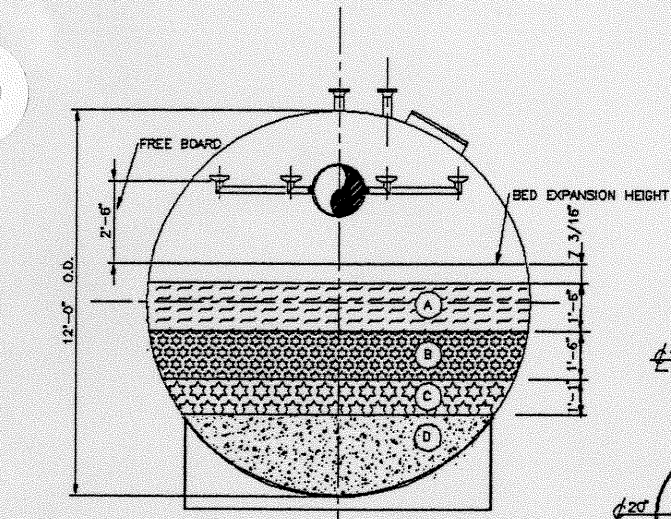

MEDIA GRADATION
SCALE: 3/8"=1'-0"

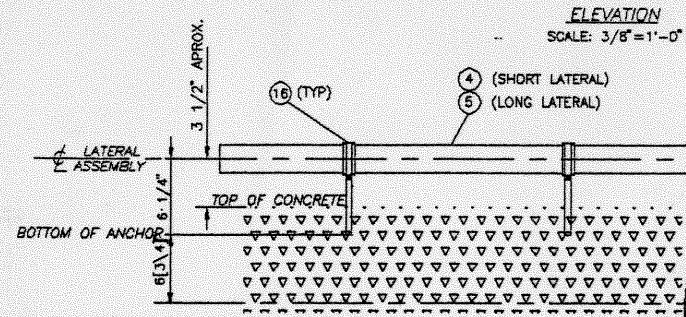

ELEVATION
SCALE: 3/8"=1'-0"

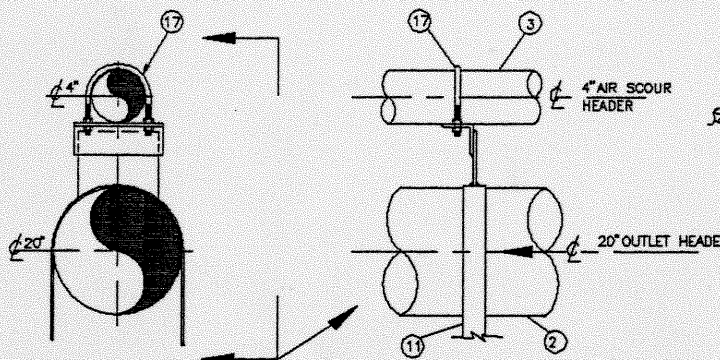

DETAIL B
TYPICAL AIR SCOUR SUPPORT
(TYP. 4)
N.T.S.

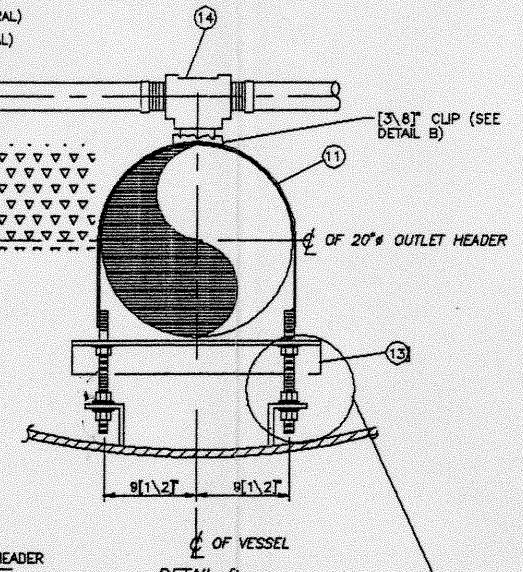

DETAIL C
TYPICAL LATERAL ASSEMBLY
(TYP. 4)
(N.T.S.)

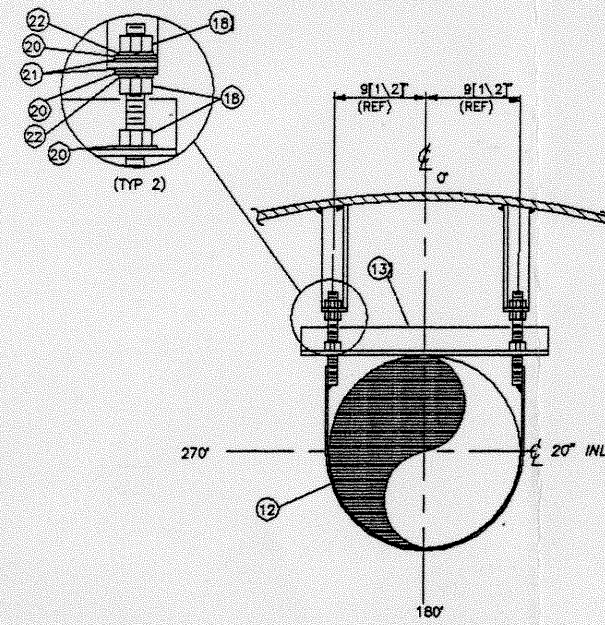

DETAIL D
INLET HEADER TIE-DOWN DETAIL
(TYP. 4)
(N.T.S.)

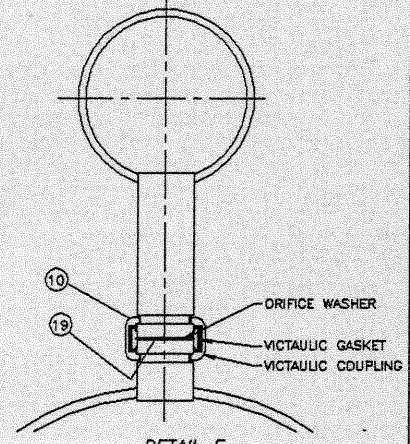

DETAIL E
AIR SCOUR HEADER DETAIL
(TYP. 11)
(N.T.S.)

- NOTES:
- INTERNAL LINING AND EXTERNAL COATING PER SPEC.
 - MEDIA TO BE INSTALLED AT SITE.
 - CONCRETE SUBFILL TO BE INSTALLED BY OTHERS AT SITE.

LEGEND
(S) - DENOTES LOCATION WHERE A SHORT DISTRIBUTION ASSY IS INSTALLED IN HEADER
(L) - DENOTES LOCATION WHERE A LONG DISTRIBUTION ASSY IS INSTALLED IN HEADER

MEDIA REFERENCE				
ITEM	TYPE	VOLUME/FILTER	NOMINAL SIZE	VOLUME SHIPPED
A	ANTHRACITE	436 FT ³	0.8 -0.9 MM	878 FT ³ (INCLUDES 5% OVERAGE)
B	FINE SAND	800 FT ³	30-40 MESH	840 FT ³ (INCLUDES 5% OVERAGE)
C	SUPPORT GRAVEL	816 FT ³	8-12 MESH	842 FT ³ (INCLUDES 5% OVERAGE)
D	CONCRETE (LOW SLUMP) BY OTHERS	800 FT ³	MINIMUM GRADE 2000 LB./CU.YD.	

DRAWING NO.	TITLE	REV	DESCRIPTION	UNLESS OTHERWISE SPECIFIED				NAME	DATE	DWG TITLE
				BY	CHKD	APPD	DATE			
INT-9016-01-01	INTERIALS FABRICATION DETAILS - HORIZONTAL MEDIA FILTER	2	AS BUILT	BT	RL	GD	5/86	MEGGITT SERCK BAKER INC	VESSEL INTERNAL ASSEMBLY HORIZONTAL DUAL MEDIA FILTER F-01 THRU F-08 144" O.D. X 43'-0" T/T	
VSL-9016-01-01	VESSEL OUTLINE - HORIZONTAL MEDIA FILTER	1	ADDED DETAIL "E"	RD	RL	GD	11/95			
		0	FINAL ISSUE FOR CONSTRUCTION	RD	RL	GD	10/95			
				BY	CHKD	APPD	DATE		SCALE: AS NOTED	

CASITAS MUNICIPAL WATER DISTRICT
LAKE CASITAS
PRESSURE FILTRATION PLANT
OAK VIEW, CALIFORNIA



**28" Access
Manway**

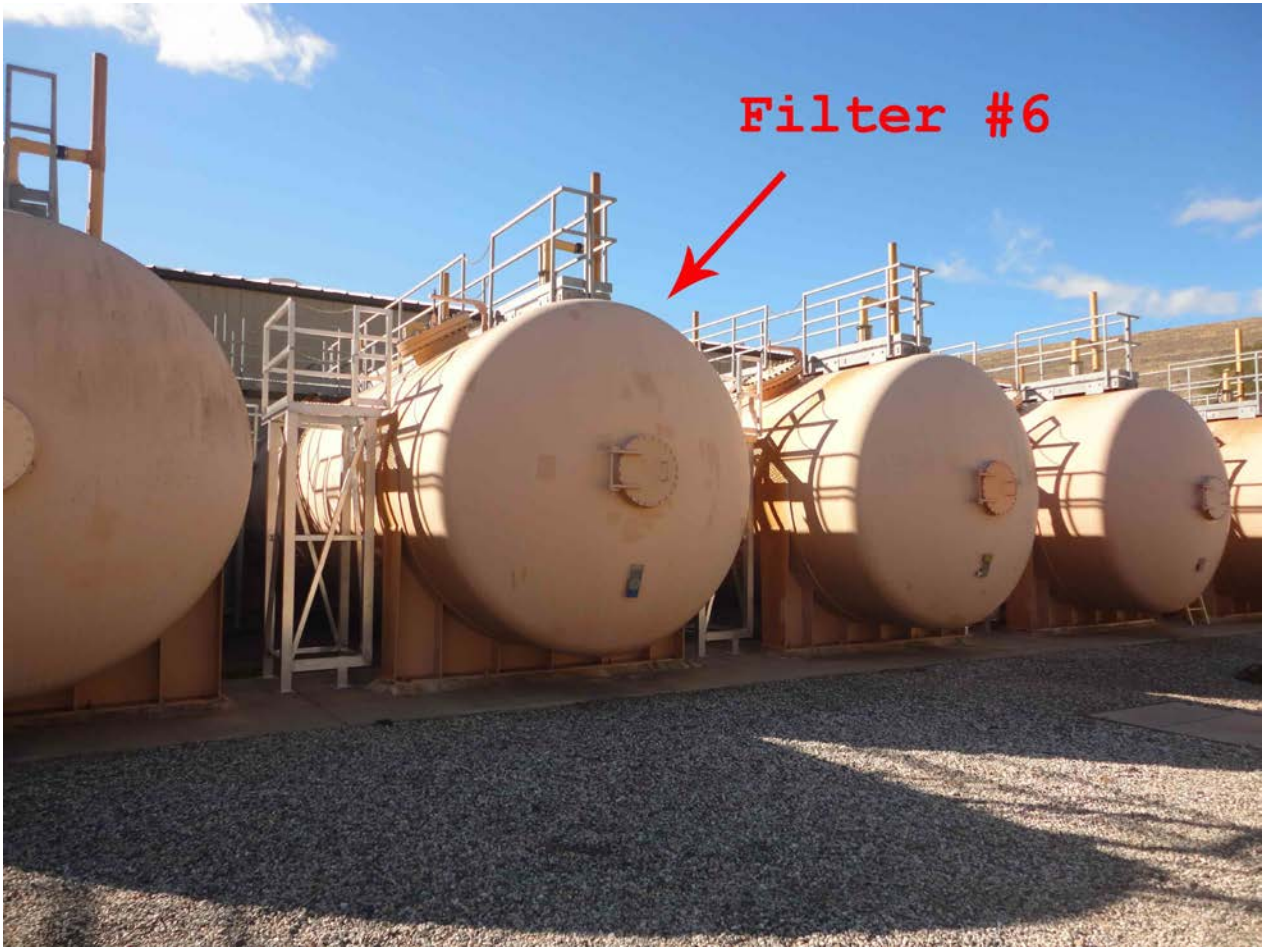

Filter #6

SPECIFICATIONS
Part B - General Conditions

1. Definitions.

(a) Whenever the words defined in this article occur in these Specifications, or in any other contract document, they shall have the meaning here defined:

(b) The word "specifications" shall include these General Conditions, the Special Conditions and the applicable portions of the Standard Specifications. The form of these Specifications is intended to provide for all of the work performed for Casitas Municipal Water District.

(c) The word "District" shall mean the Casitas Municipal Water District.

(d) The word "Board" shall mean the Board of Directors of the Casitas Municipal Water District.

(e) The words "General Manager" shall mean the person holding the position or acting in the capacity of General Manager of the Casitas Municipal Water District.

(f) The word "Engineer" shall mean the General Manager, or his duly authorized representative.

(g) The word "Contractor" shall mean the Contractor in the agreement for the construction of the work and/or the furnishing of materials and/or equipment herein specified, the legal representative, or the agent of said party.

(h) The word "Subcontractor" shall mean one who, as a subcontractor, performs at the site of the work some part of the Contractor's obligation, the legal representative, or the agent therefor.

(i) The words "Standard Specifications" shall mean the provisions of the latest edition of the Standard Specifications for Public Works Construction (SSPWC) with all supplements, prepared and promulgated by the Southern California Chapters of the American Public Works Association and Associated General Contractors of America. Part one of the SSPWC is hereby deleted.

2. Contract Documents.

(a) The Notice Inviting Bids, Instructions to Bidders, Proposal Bonds, Specifications and Drawings, with the Agreement, supplemental notices, Notice to Proceed, permits and change orders shall be considered as incorporated in the contract. The contract documents are complementary, and what is called for in one shall be as binding as if called for by all. The intent of the contract documents is to provide for the execution and completion of a finished piece of work. The Contractor shall provide all labor and services and furnish all materials and equipment as necessary, except those items definitely stipulated in the Specifications or Drawings to be furnished by the District. Anything shown in the Drawings and not the Specifications, or in the Specifications and not the Drawings, shall be performed by the Contractor as though shown in both the Drawings and the Specifications.

(b) The Drawings and the Specifications show conditions as they exist, to the best knowledge and belief of the District. The Contractor shall not be relieved of any liability or responsibility under this

contract, and the district or any of its officers shall not be liable for any loss sustained by the Contractor because of any variation between conditions as shown on the Drawings and the actual conditions revealed during the progress of the work, except as provided in Section 4215 of the Government Code.

3. Precedence of Contract Documents.

(a) Should conflicts occur between Contract Documents, the document highest in precedence shall control. The precedence shall be:

- (1) Permits from other agencies as may be required by law.
- (2) Proposal.
- (3) Special Conditions and Measurement and Payment.
- (4) Technical Conditions.
- (5) General Conditions
- (6) Contract Drawings.
- (7) Standard Plans.
- (8) Standard Specifications.
- (9) Reference Specifications.

(b) Change orders, supplemental agreements and approved revisions to plans and specifications will take precedence over documents listed above. Detailed plans shall have precedence over general plans.

4. Indemnification of District. Contractor shall indemnify and hold harmless and defend the United States Bureau of Reclamation, the District, their directors, employees, agents or volunteers, and each of them from and against:

(a) Any and all claims, demands, causes of action, damages, costs, expenses, losses or liabilities, in law or in equity, of every kind and nature whatsoever for, but not limited to, injury to or death of any person including District and/or Contractor, or any directors, officers, employees, agents or volunteers of District or Contractor, and damages to or destruction of property of any person, including but not limited to, District and/or Contractor and their directors, officers, employees, agents or volunteers, arising out of or in any manner directly or indirectly connected with the work to be performed under this agreement, however caused, regardless of any negligence of District or its directors, officers, employees, agents or volunteers, except the sole negligence or willful misconduct or active negligence of District or its directors, officers, employees, agents or volunteers.

(b) Any and all actions, proceedings, damages, costs expenses, penalties or liabilities, in law or equity, of every kind or nature whatsoever, arising out of resulting from, or on account of the violation of any governmental law or regulation, compliance with which is the responsibility of Contractor.

Contractor shall defend, at Contractor's own cost, expense and risk, any and all such aforesaid suits, actions or other legal proceedings of every kind that may be brought or instituted against District or District's directors, officers, employees, agents or volunteers.

Contractor shall pay and satisfy any judgment, award or decree that may be rendered against District or its directors, officers, employees, agents or volunteers, in any such suit, action or other legal proceeding.

Contractor shall reimburse District and its directors, officers, employees, agents and/or volunteers, for any and all legal expenses and costs incurred by each of them in connection therewith or in enforcing the indemnity herein provided.

Contractor agrees to carry insurance for this purpose as set out in the specifications.

5. Insurance.

(A) Contractor shall provide and maintain the following commercial general liability and automobile liability insurance:

(1) Coverage for commercial general liability and automobile liability insurance shall be at least as broad as the following:

- a. Insurance Services Office Commercial General Liability coverage (Occurrence Form CG 0001).
- b. Insurance Services Office Form Number CA 0001 (ed. 1/87) covering Automobile Liability, Code 1 (any auto).

(2) The Contractor shall maintain limits no less than the following:

- a. General Liability. One million dollars (\$1,000,000) per occurrence for bodily injury, personal injury and property damage. If Commercial General Liability Insurance or other form with a general aggregate limit is used, either the general aggregate limit shall apply separately to the project/location (with the ISO CG 2501 or insurers equivalent endorsement provided to the district) or the general aggregate limit shall be twice the required occurrence limit.
- b. Automobile Liability. One million dollars (\$1,000,000 per accident for bodily injury and property damage combine single limit.

(3) The general liability and automobile liability policies are to contain, or be endorsed to contain the following provisions:

- a. The United States Bureau of Reclamation, Casitas Municipal Water District, their directors, officers, employees, agents and volunteers are to be covered as insureds as respects: liability arising out of activities performed by or on behalf of the Contractors, products and completed operations of the Contractor; premises owned, occupied or used by the Contractor; or automobiles owned, leased, hired or borrowed by the Contractor. The coverage shall contain no special limitations on the scope of protection afforded to the United States Bureau of Reclamation, Casitas Municipal Water District, its directors, officers, employees, agents and volunteers.
- b. For any claims related to this project, the Contractor's insurance shall be primary insurance as respects the United States Bureau of Reclamation, Casitas Municipal Water District, their directors, officers, employees, agents and volunteers. Any insurance or self-insurance maintained by the United States Bureau of Reclamation,

Casitas Municipal Water District, their directors, officers, employees, agents and volunteers shall be excess of the Contractor's insurance and shall not contribute with it.

- c. Any failure to comply with reporting or other provisions of the policies including breaches of warranties shall not affect coverage provided to the United States Bureau of Reclamation, Casitas Municipal Water District, their directors, officers, employees, agents and volunteers.
- d. The Contractor's insurance shall apply separately to each insured against whom claim is made or suit is brought, except with respect to the limits of the insurer's liability.
- e. Each insurance policy required by this clause shall be endorsed to state that coverage shall not be suspended, voided, canceled by either party, reduced in coverage or in limits except after thirty (30) days prior to written notice by certified mail, return receipt requested, has been given to Casitas Municipal Water District.
- f. Such liability insurance shall indemnify the Contractor and his subcontractors against loss from liability imposed by law upon, or assumed under contract by, the Contractor or his subcontractors for damages on account of such bodily injury (including death), property damage, personal injury and completed operations and products liability. Such insurance shall be provided on a policy written by underwriters through an agency satisfactory to the District (see Section 4-08.05), which includes a cross-liability clause, and covers bodily injury and property damage liability, owned and non-owned vehicles and equipment, blanket contractual liability and completed operations liability. Such liability insurance shall include explosion, collapse, underground excavation and removal of lateral support. The United States Bureau of Reclamation, Casitas Municipal Water District, their directors, officers, employees agents and volunteers shall be named as additional primary insured on any such policies. An additional insured endorsement (ISO CG 2010 or equivalent) (modified to include provisions 2-5 above) and a certificate of insurance (Accord Form 25-S or equivalent), shall be provided to the District.

(4) Any deductible or self-insured retention must be declared to and approved by the District. At the option of the District, either the insurer shall reduce or eliminate such deductibles or self-insured retentions as respects the United States Bureau of Reclamation, Casitas Municipal Water District, their directors, officers, employees, agents and volunteers; or the Contractor shall procure a bond guaranteeing payment of losses and related investigations, claim administration and defense expenses.

(5) Insurance is to be placed with insurers having a current A.M. Best's rating of no less than A:VII or equivalent.

(6) The Contractor shall not commence work under this contract, nor allow any subcontractor to commence work on this subcontract, until he has secured all insurance required under the section and has filed with the District, certificates of insurance in the amounts specified. Such certificates shall contain a provision that they may not be called without at least thirty (30) days' written notice to the District.

(B) Worker's Compensation Insurance.

(1) By his signature hereunder, Contractor certifies that he is aware of the provisions of Section 3700 of the Labor Code which require every employer to be insured against liability for worker's compensation or to undertake self-insurance in accordance with the provisions of that code, and he will comply with such provisions before commencing the performance of the work of this contract.

(2) The Contractor shall maintain, and shall cause all subcontractors he may employ to maintain adequate workers compensation insurance under the laws of the State of California for all labor employed by them, directly or indirectly, in the execution of the work. The Contractor and all subcontractors shall file with the District certification of such workers compensation insurance prior to beginning construction.

(C) Evidences and Cancellation of Insurance.

(1) Prior to execution of the contract, the Contractor shall file with the District evidence of insurance from an insurer or insurers certifying to the coverage of all insurance required herein. Such evidence shall include the ISO CG 2010 (or insurer's equivalent) signed by the insurer's representative and certificate of insurance (Accord Form 25-S or equivalent). All evidence of insurance shall be certified by a properly authorized officer, agent or qualified representative of the insurer and shall certify the names of the insured, any additional primary insurers, where appropriate, the type and amount of the insurance, the location and operations to which the insurance applies, the expiration date, and that the insurer will give by certified mail, written notice to the District at least thirty (30) days prior to the effective date of any cancellation, lapse or material change in the policy.

(2) The Contractor shall, upon demand of the District, deliver to the District all such policy or policies of insurance and the receipts for payment or premiums thereon; and should the Contractor neglect to obtain and maintain in force any such insurance or deliver such policy or policies and receipts to the District, then it shall be lawful for the District to obtain and maintain such insurance, and the Contractor hereby appoints the District his true and lawful attorney-in-fact to do all things necessary for this purpose. All money paid by the District for insurance premiums under the provisions of this article shall be charged to the Contractor.

6. Bonds.

(a) Payment Bond. The successful bidder shall file with the District a surety bond to be approved by the District in a sum of not less than one hundred percent (100%) of the total amount payable by the terms of the contract, conditional as provided by Section 3247 of the Civil Code.

(b) Performance Bond.

(1) The successful bidder shall also file with the District a surety bond, to be approved by the District in a sum of not less than one hundred percent (100%) of the total amount payable by the terms and conditions of the Contract. Pursuant to Public Contract Code Section 22300, at the request and expense of the Contractor, securities equivalent to the amounts withheld by the District to ensure performance under this contract, shall be deposited with the District. The District shall pay such monies to the Contractor upon satisfactory completion of the contract. Securities eligible for investment under this section shall include those listed in Government Code Section

16430, or bank or savings and loan certificates of deposit. The Contractor shall be the beneficial owner of any securities substituted for monies withheld and shall receive any interest thereon. If the securities to be deposited by the Contractor pursuant to this provision are in registered form, the registration shall be transferred to the District.

- (2) Maintenance and Guarantee. The Contractor hereby guarantees that the entire work constructed by him under the Contract will meet fully all requirements thereof as to quality of workmanship and of materials furnished by him. The Contractor hereby agrees to make, at his own expense, any repairs or replacement made necessary by defects in material or workmanship supplied by him that becomes evident within one year after the date of final payment, and to restore to full compliance with the requirements of these Specifications, any part of the work which, during said one year period, is found to be deficient with respect to any provision of the Specifications. The Contractor shall make all repairs and replacement promptly upon receipt of written orders from the Engineer to do so. If the Contractor fails to make the repairs and replacements promptly, the District may do the work and the Contractor and his Surety shall be liable to the District for the cost thereof.

(c) Each of said bonds shall be executed by the Contractor and a corporate surety licensed in the State of California. If the amount payable under terms of the Contract exceeds the original bid because of additional quantities and/or the issuance or change orders, said surety shall be required to cover the additional amount.

7. Additional Surety. If, during the continuance of the Contract, any of the sureties upon the faithful performance bond, in the opinion of the Engineer, are or become insufficient, he may require additional sufficient sureties, which the Contractor shall furnish to the satisfaction of the Engineer within 15 days after notice, and in default thereof, the contract may be suspended and the work completed as provided in Section 21 hereof.

8. Assignment Forbidden. The Contractor shall not assign, transfer, convey or otherwise dispose of this Contract, nor of his right, title or interest in any part thereof, nor any of the monies to become due and payable under the Contract, in any manner without the previous consent in writing of the Engineer. If the Contractor shall, without such written consent, assign, transfer, convey or otherwise dispose of any part of this Contract, or of any of the monies to become due and payable under the Contract, the District may, at its option, terminate the Contract according to Section 21 of these General Conditions. The District shall thereupon be relieved from all liability to the Contractor, and to his assignee or transferee.

9. Time and Order of Work. The Contractor shall at all times employ such personnel, and provide such services, materials and equipment as will be sufficient, in the opinion of the Engineer, to complete the work or any separable portions thereof according to a progress schedule, and within the time limit fixed by the Contract. If the Contractor should fail to maintain adequate progress, he may be required to employ additional personnel, and provide additional services, materials and equipment, and to modify his plans and procedure in such manner as to ensure completion of the work within the time limit fixed by the Contract. This provision shall not be the exclusive remedy of the District.

10. Protests. If the Contractor considers any of the work demanded of him to be outside the requirements of the Contract, or if he considers any order or ruling of the Engineer or any duly authorized representative to be unfair, he shall immediately ask for written instructions or divisions, whereupon he shall proceed without delay to perform the work or conform to the order or ruling; but unless the Contractor finds such instructions or divisions satisfactory, he shall, within ten (10) days after receipt of same, file a written protest with the Engineer, stating clearly and in detail his objections and the reasons therefor. Except for such grounds for protest or objections as are made of record in the manner specified and within the time stated herein, the Contractor hereby waives all grounds for protests or objections to the order, rulings, instructions, or decisions of the Engineer, and hereby agrees that as to all matters not included in such protest, the order, instructions and decisions of the Engineer shall be final and conclusive.

11. Authority of the Engineer. The work shall be observed by the Engineer to determine that the work is being completed according to the plan, specifications and design and planning concepts. The Contractor shall be responsible for the supervision of construction processes, site condition, operation, equipment, personnel and the maintenance of a safe place to work or any safety in, on or about the work site until such time as the District files a Notice of Completion. The Engineer, however, reserves the right to determine the adequacy of the Contractor's method, plant, and appurtenance to determine in all cases the amount, quality, acceptability and fitness of the work and material to be provided under the Contract, to determine all questions in relation to said work and construction thereof, and to decide in all cases any question which may arise concerning the fulfillment of this Contract by the Contractor. Should any discrepancy appear or any misunderstanding arising as the import of anything contained in the Specifications or Drawings, the matter shall be referred to other Engineer and his decision shall be binding on the Contractor. Any differences or conflicts which may arise between the Contractor and other contractors performing work for the District shall be adjusted to the satisfaction of the Engineer.

12. Right of Way and Encroachment.

(a) Except as otherwise stated in the Special Conditions, the right of way for the work to be constructed under these Specifications will be provided by the District. This shall not be interpreted as giving the Contractor exclusive occupancy of the right of way provided. When the work to be performed is located within State Highway, County or Southern Pacific Railroad rights of way, or within a water course which is under the jurisdiction of the Ventura County Flood Control District, the Contractor will be required to obtain construction permits from those agencies in his own name.

(b) Right of way to be furnished by the District for construction operations and other purposes will be specifically shown on the Drawings or provided for in the Detailed Specifications. Should the Contractor find it necessary to use any additional lands during the construction of the work, he shall provide for the use of such lands at his own expense.

13. Errors or Discrepancies Noted by Contractor.

(a) If the Contractor, either before commencing work or during the work, finds any discrepancy between these Specifications and Drawings, or between either of them and the physical conditions at the site of the work, or finds any error or omission in any of the Drawings or in any survey, he shall promptly notify the Engineer in writing of such discrepancy, error, or omission. If the Contractor observes that any drawings or specifications are at variance with any applicable law, ordinance, regulations, order or degree, he shall promptly notify the Engineer, in writing, of such conflict.

(b) The Engineer, upon receipt of any such notice, shall promptly investigate the circumstances and give appropriate instructions to the Contractor. Until such instructions are given, any work done by the Contractor, either directly or indirectly after his discovery of such error, discrepancy or conflict, will be at his own risk and he shall bear all costs arising therefrom.

14. Extra Work.

(a) If, during the performance of the Contract, it shall, in the opinion of the Engineer, become necessary or desirable, for the proper completion of the contract, to order work done or materials or equipment furnished which, in the opinion of the Engineer, are not susceptible of classification under the bid items, the Contractor shall do and perform such work and furnish such materials and equipment as extra work, as hereinafter provided. All extra work shall be ordered in writing before it is started. No extra work shall be paid for unless ordered in writing.

(b) Extra work will ordinarily be paid for at a lump sum or unit price agreed upon in writing by the Engineer and the Contractor before the extra work shall be ordered.

(c) When the price of the extra work cannot be agreed upon, the District will pay for the extra work based on the accumulation of costs as provided in subsections (d) through (I). The failure of the Contractor to comply with the requirements of this section shall deem the Engineer to establish costs as he deems reasonable.

(d) At the close of each working day, the Contractor shall submit a daily report to the Engineer, on forms approved by the District, together with applicable delivery tickets, listing all labor, materials, and equipment involved for that day, and for other services and expenditures when authorized. An attempt shall be made to reconcile the report daily, and it shall be signed by the Engineer and the Contractor. In case of disagreement, pertinent notes shall be entered by each party to explain points which cannot be resolved immediately. Each party shall retain a signed copy of the report. Reports by subcontractors or others shall be submitted through the prime contractor. Said reports shall contain the following information:

- (1) The names of workers, classification and hours worked;
- (2) A description and the amount of materials used;
- (3) The type of equipment, size, identification number and hours of operation, including loading and transportation if available;
- (4) Other services and expenditures shall be described in such detail as the District may require.

(e) The costs of labor will be the actual cost for wages prevailing locally for each craft or type of worker at the time the extra work is done, plus employer payments of payroll taxes and insurance, health and welfare, pension, vacation, apprenticeship funds, and other direct costs resulting from Federal, State or local laws, as well as assessment or benefits required by lawful collective bargaining agreements. The use of a labor classification which would increase the extra work costs will not be permitted unless the Contractor establishes the necessity for such additional costs. Labor costs for equipment operators and helpers shall be reported only when such costs are not included in the invoice for equipment rental.

(f) The cost of materials reported shall be at invoice or lowest current price at which such materials are locally available and delivered to the job site in the entities involved, plus sales tax, freight and delivery. The District reserves the right to approve material sources of supply, or to supply materials to the Contractor if necessary for the progress of the work. No markup shall be applied to any material provided by the District.

(g) No payment will be made for the use of tools which have a replacement value of \$100 or less. Regardless of ownership, the rates to be used in determining equipment rental costs shall not exceed listed rates prevailing locally at equipment rental agencies or distributors, at the time the work is performed. If local rental costs are unavailable, the Contractor shall submit his costs to operate the equipment compiled and signed by a Certified Public Accountant. The rental rates paid shall include the cost of fuel, oil, lubrication, supplies, small tools, necessary attachments, repairs and maintenance of any kind, depreciation, storage, insurance and all incidentals. Necessary loading and transportation costs for equipment used on the extra work shall be included. If equipment is used intermittently and, when not in use, could be returned to its rental source at less expense to the District than holding it at the work site, it shall be returned, unless the Contractor elects to keep it at the work site at no expense to the District. All equipment shall be acceptable to the Engineer, in good working condition, and suitable for the purpose for which it is to be used. Manufacturer's ratings and manufacturer's approved modifications shall be used to classify equipment, and it shall be powered by a unit of at least the minimum rating recommended by the manufacturer. The reported rental time of the equipment already at the job site shall be the duration of its use on the extra work, plus the time required to move it from its previous site and back or to a closer site.

(h) The District may authorize other items which may be required on the extra work. Such items include labor, services, material, and equipment which are different in their nature from those required for the work specified in the Contract which are of a type not ordinarily available from the Contractor or any of the subcontractors. Invoices covering all such items in detail shall be submitted with the request for payment.

(i) Vendors' invoices for material, equipment rental, and other expenditures, shall be submitted with the request for payment. If the request for payment is not substantiated by invoices or other documentation, the District may establish the cost of the item involved at the lowest price which was current at the time of the report.

(j) The following percentage shall be added to the Contractor's costs and shall constitute the markup for all overhead and profits:

Labor	10%
Materials	10%
Equipment Rental	10%
Other Items and Expenditures	10%

To the sum of the costs and markups provided for in this subsection, one percent (1%) shall be added as compensation for bond and liability insurance.

(k) When all or any part of the extra work is performed by any of the Contractor's subcontractors, the markups established in Subsection (14)(j) shall be applied to the subcontractor's actual cost of such work, to which a markup of five percent (5%) on the subcontracted portion of the extra work may be added by the prime contractor.

(1) Any extra work performed hereunder shall be subject to all of the provisions of the Contract and the Contractor's sureties shall be bound with reference thereto as under the original Contract.

15. Changed Conditions.

(a) The Contractor shall notify the Engineer in writing of the following work site conditions, hereinafter called changed conditions, promptly upon their discovery and before they are disturbed:

- (1) Subsurface or latent physical conditions differing materially from those represented in the Contract; and
- (2) Unknown physical conditions of an unusual nature differing materially from those ordinarily encountered and generally recognized as inherent in the character of the work being performed.
- (3) Material that the Contractor believes may be material that is hazardous waste, as defined in Section 25117 of the Health and Safety Code, that is required to be removed to a Class I, Class II, or Class III disposal site in accordance with provisions of existing law.

(b) The Engineer will promptly investigate conditions when notified of any conditions which appear to be changed conditions. If the Engineer determines that the conditions are changed conditions and that they will materially increase or decrease the costs of any portion of the work, a change order will be issued adjusting the compensation for such portion of the work. If the Engineer determines that conditions of which he/she has been notified by the Contractor do not justify an adjustment in compensation, the Contractor will be so advised in writing. Should the Contractor disagree with such determination, he may submit a protest to the Engineer, as provided in Section 10 of these General Conditions.

(c) If the Engineer determines that the conditions are changed conditions and that they will materially affect the performance time, the Contractor, upon submitting a written request, may be granted an extension of time subject to the provisions of Section 22.

(d) The Contractor's failure to give notice of changed conditions promptly upon their discovery and before they are distributed shall constitute a waiver of all claims in connection therewith.

16. Disputed Work.

(a) If unable to reach agreement under any of the foregoing procedures, the District may direct the Contractor to proceed with the work. Payment shall be as later determined by arbitration, if District and Contractor agree thereto, or as fixed in a court of law.

(b) Although not to be construed as proceeding under extra work provisions, the Contractor shall keep and furnish records of disputed work according to Section 14.

17. Legal Action by Contractor.

(a) No legal action shall be commenced against the District concerning the Contract until any dispute or decision of the Engineer has been appealed and denied by the District's Board of Directors. The Board's refusal to consider or failure to consider a written appeal within thirty (30) calendar days after receipt shall be deemed denial of such appeal.

(b) Prior to submitting any appeal to the Board, the Contractor shall exhaust his administrative remedies by attempting to resolve his dispute with the District's staff in the following sequence:

Construction Inspector
District Engineering
General Manager
Board of Directors

(c) Should any of the listed persons fail to consider a request by the Contractor for reconsideration of a decision within three (3) working days after receiving written request to do so, the Contractor may proceed directly to the next person in the list. At the option of the District, the person to whom the request for reconsideration is directed may elect to take such request to a higher level and the Contractor's request shall be deemed to be properly submitted to such higher level.

(d) Nothing in this subsection shall be considered as relieving the Contractor from his duties required by the Contract documents.

18. Changes.

(a) If either the Engineer or the Contractor, because of conditions which develop during the progress of the work, finds it impracticable to comply strictly with these Specifications, the Engineer may prescribe a modification of requirements or methods of work. For such proposes, the Engineer may, any time during the life of the Contract, by written order, make such changes, as he shall find necessary, in the design, engineer, grade, form, location, dimensions, plan, or material of any part of the work or equipment to be furnished. If such changes increase or diminish the quantity of work to be done, they shall not constitute the basis for a claim for damages or anticipated profits in the work that may be dispensed with; provided that if such changes or alterations render useless any work already done or materials already furnished or used in the work, the Engineer shall make reasonable allowance therefore, which action shall be binding upon both parties.

(b) In case of increasing or decreasing of work, the total amount of work actually done or materials or equipment furnished shall be paid for according to the unit price established for such work under the contract, wherever such unit price has been established. In the event no prices are named in the Contract but cover such changes or alterations, the cost of such changes shall be determined as provided in Section 14(c).

19. Discovery of an Unknown Utility.

(a) The Contractor's attention is directed to Section 4215 of the Government Code which provides that the district assumes the responsibility for the removal, relocation or protection of the existing

utilities located on the site of any construction project if such utilities are not identified by the District in the plans and specifications made a part hereof.

(b) If the Contractor, while performing the Contract, discovers utility facilities not identified by the District in the Contract plans and specifications, the Contractor shall immediately notify the District. The Contractor shall not be assessed liquidated damages for delay in completion of the project, which such delay is caused by the failure of the District or the owner of the utility to provide for removal or relocation of the existing utility facilities.

(c) In the event that the discovery of said utility facilities may cause extra work, the Contractor is required to obtain written authorization to change or modify the work according to Sections 14 and 18 of these General Conditions, entitled "Extra Work" and "Changes," respectively.

(d) The Contractor's failure to give said notice promptly upon discovery of an unknown utility or the Contractor's failure to obtain written approval for any work concerning the relocation, protection and/or removal of the said unknown utility or for any work relative to the modification of any portion of the work prior to the beginning of any of said work, shall constitute a waiver of any rights to any claim in connection therewith.

20. Termination of Contract.

(a) General. If, at any time before completion of work under the contract, it shall be found by the District that reasons beyond the control of the parties hereto render it impossible, or against the best interest of the District, to complete the work contracted to be done; or if the work shall have been prevented or suspended by injunction issued by a court of competent jurisdiction nor by any other order of constituted authority for a period in excess of 30 consecutive days; the District, by written thirty (30) day notice to the Contractor, may discontinue the work and terminate the contract; or, in the event the entire work shall have been suspended by the District, through no fault of the Contractor, in writing, the Contract shall be discontinued. Upon the service of notice of termination, the Contractor shall discontinue the work in such manner, sequence, and at such times as the Engineer may direct, continuing and doing, after said notice, only such work and only until such time or times as the Engineer may direct. Such work shall be paid for as extra work according to Section 14 of these General Conditions. The Contractor shall have no claim for damages for such discontinuance or termination of the Contract, nor shall the Contractor have any claim for anticipated profits on the work thus dispensed with, nor any other claim; except: (1) for the work actually performed between the date of the notice of termination and the time of complete discontinuance; and (2) for any liquidated damages accruing up to the date of said notice of termination according to the provisions of the Special Conditions.

(b) Consumable Supplies. In the event of discontinuance and termination of the contract, the District may, and at the request of the Contractor shall, purchase from the Contractor all consumable supplies of the Contractor on hand, or in transit, or on definite commitment which, in the opinion of the Engineer, are suitable and required, except for such discontinuance and termination, to complete the work, and the District shall pay the Contractor for such consumable supplies the prices paid therefor by the Contractor.

(c) Completion of Contract. In the event that the work shall be discontinued and the Contract terminated, the satisfactory completion of such work, as the Engineer may thereafter direct, and satisfactory compliance with the terms of said order shall be deemed the completion of the work specified in the

Contract; and the final estimate shall be the amount of work completed to the time of such discontinuance and termination, with such other sums as may be due the Contractor according to the provisions of this section.

21. Suspension of Contract.

(a) If the work to be done under the Contract shall be abandoned by the Contractor, or if the Contractor shall make a general assignment for the benefit of his creditors or be adjudicated as bankrupt, or if a receiver of his property or business be appointed by a court of competent jurisdiction, or if this Contract shall be assigned by him otherwise than hereinbefore specified, or if at any time the Engineer shall be of the opinion that the performance of the contract is unnecessarily or unreasonably delayed, or that the Contractor is willfully violating any of the conditions of the Contract, or is executing the same in bad faith or not according to the terms thereof, or if the work be not fully completed within the time named in the Contract for its completion or within the time to which the completion of the Contract may have been extended as hereinafter provided, the Board may, by written notice, instruct the Contractor to discontinue all work, or any part thereof, under this Contract.

(b) When such written notice is served upon the Contractor, he shall immediately discontinue the work or such part thereof as covered by the notice, and shall not resume the same by written notice from the Board, in which case work shall be resumed in ten (10) days. In any such case, the District may take charge of the work and complete it by a new contract or by force account and charge the expense of completion by either method to the Contractor. In so doing, the District may take possession of and use any of the materials, plans, tools, equipment, supplies and property of every kind provided by the Contractor for the purpose of his work. Any such charges shall be deducted from such monies as may be due or may at any time hereafter become due the Contractor under this contract or at any part thereof. In case such expense shall exceed the amount which would have been due the contractor under the Contract if the same had been completed by him, he shall pay the amount of such excess to the District; and in case such expense shall be less than the amount which would have been payable under this contract if the same had been completed by the Contractor, he shall have no claim to the difference except to such extent as may be necessary, in the opinion of the Engineer, to reimburse the Contractor or the Contractor's sureties for any expense properly incurred for plans, equipment, materials, supplies and labor devoted to the prosecution of the work, of which the District shall have received the benefit which shall not have been otherwise paid for by the District. In computing such expense the salvage value of such plans and equipment, at completion of the work, shall be deducted from the depreciated value thereof at the time taken over by the District and the difference shall be considered the expense. All necessary estimate and appraisals shall be made by the Engineer.

(c) When any particular part of the work is being carried on by the District, by Contract or otherwise, under the provisions of this section, the Contractor shall continue the remainder of the work in conformity with the terms of the Contract, and in such a manner as to nowise hinder or interfere with the persons or workers employed, as provided above, by the District, to do any part of the work, or to complete the same under the provisions of this section.

22. Extension of Time of Completion.

(a) If the work shall be delayed in consequence of suspension by the District except as provided in Section 21 or of failure by the District to provide right of way, or of any other act or omission of the District, or by strikes, acts of God, delay of delivery or properly ordered materials for which a delivery time has not been stated in the Proposal, or other unforeseeable causes beyond the control and without the fault or negligence of the Contractor or his subcontractors, the Contractor shall be entitled to so much additional time wherein to perform and complete the contract on his part as the Engineer shall certify in writing to be just.

(b) Application for extension of time must be made to the Engineer, in writing, stating cause, within the ten (10) days immediately following the end of such delay.

(c) Permitting the Contractor to continue and finish the work, or any part of it, after the date to which the time fixed for its completion may have been extended, shall in no way operate as a waiver on the part of the District of any of its rights under this Contract.

(d) The Contractor shall receive no compensation on account of any suspension of the work either in whole or in part or for any delay or hindrance herein mentioned except as provided in the Special Conditions.

(e) No extension of time shall be made for ordinary delays and accidents and the occurrence of such shall not relieve the Contractor from the necessity of maintaining the required progress. In the case of an extension of time by the Engineer for completion of the contract as provided for in these Specifications, a revised schedule of progress may be prescribed according to such extension of time.

23. Failure to Complete on Time.

(a) The Contractor shall pay for each and every calendar day that he shall be in default in completing the whole work to be done under this contract, the sum named in these conditions, which sum is by the execution of this agreement mutually agreed upon as liquidated damages which the District shall suffer by reason of such default. The District shall have the right to deduct the amount of such damages from any monies due or to become due the Contractor under this Contract.

(b) The Contractor shall not be assessed liquidated damages for failure to complete the work on time due to any of the causes stated in Section 22(a).

24. Liquidated Damages.

(a) Pursuant to Section 23 of these General Conditions, failure of the Contractor to complete the work within the time allowed will result in damages being sustained by the District. Such damages are, and will continue to be, impractical and extremely difficult to determine. For each consecutive calendar day in excess of the time specified for completion of the work (as adjusted by change order), the Contractor shall pay the District, or have withheld from monies due it, the sum of \$500, except as otherwise specified in Part C or the Agreement.

(b) Execution of the Contract under these Specifications shall constitute agreement by the District and Contractor that \$500 per day, except as otherwise specified in Part C or the Agreement, is the

minimum value of the costs and actual damage caused by failure of the Contractor to complete the work within the allotted time, that such sum is liquidated damages and shall not be construed as a penalty, and that such sum may be deducted from payments due the Contractor if such delay occurs.

25. Contractor's Responsibility.

(a) The contractor shall be responsible for safe and efficient execution of the work to secure the safety of the workers, the quality of the work and the stipulated rate of progress.

(b) The Contractor shall bear all losses resulting to him no account of the amount or character of the work, or from any unforeseen obstruction or difficulties which may be encountered, or because of weather, floods, or other causes, except as follows:

- (1) The Contractor shall not be responsible for the cost of repairing or restoring damage to the work which damage was caused by an act of God, as defined in Public Contract Code Section 7105, and shall be the basis for determining the extent of the District's liability, if any.
- (2) It shall be the responsibility of the Contractor to take all reasonable and adequate measures to protect the work from damage and/or to minimize any damage to the work.
- (3) The District reserves the right to make changes in the plans and Specifications applicable to the portion of the work to be restored. The District reserves the right to terminate the Contract and relieve the Contractor of further obligations to perform the work. In the event that the work damaged is to be repaired or restored either, in kind or changed by the engineer, a contract change order will be provided according to Sections 14 and 18 of the General Conditions of this Specification. The change order may provide for the Contractor to perform any work deemed by the Engineer as necessary to put the project in satisfactory condition for the termination of all work.
- (4) The District may require the Contractor to submit as a separate bid item the insurance premium covering the cost of work destroyed in whole or in part by an "Act of God," as defined in Public Contract Code 7105 and provide such insurance to indemnify the District for any damage to the work caused by an "Act of God," and to rebuild said work with the proceeds of said insurance. If the District elects to do so, said insurance shall be in lieu of the provision of the Public Contract Code 7105.

(c) The Contractor shall be responsible for all material, except defective material, furnished by the District, and for the care of all work until its completion and final acceptance, and he shall at his own expense replace damaged, lost or stolen material and repair damaged parts of the work, or the same may be done at his expense by the District.

(d) During the progress of the work, the Contractor shall keep the premises occupied by him in a neat and clean condition. When the work is completed he will be required to remove all debris caused by him in his operations, repair all damage to existing improvements done by him or his employees and leave the site of the work in a neat condition. In the event of his failure to do so, the same may be done at his expense by the District.

(e) The Contractor shall be responsible for all damage or injury which may be caused on any property by trespass of the Contractor's employees during their employment, whether the said trespass was committed with or without the consent or knowledge of the Contractor.

(f) The Contractor shall provide at his own expense, all necessary water, telephone, and power required for his operations under the Contract, except as provided for in the Special Conditions.

(g) The Contractor shall so conduct his operations as not to close or obstruct any portion of any highway, road, or street, or prevent in any way free access to fire hydrants until permission to do so has been obtained from the proper authorities.

(h) The Contractor shall be responsible for determining the nature and extent of any simultaneous, collateral, and essential work by others. The Contractor shall coordinate his operation and cooperate with others to minimize interferences, conflicts, and/or any other related conduct during the construction of the work.

26. Shop Drawings.

(a) Drawings and prints of articles, machinery, or fabricated materials entering into permanent construction which are required to be furnished by the Contractor and for which detailed drawings are not furnished by the District, the Contractor shall submit five (5) copies for approval, three (3) of which will be returned to the Contractor for his distribution, the two (2) other copies shall become the property of the District. The District shall approve such drawings or return them to the Contractor with requirements for approval within ten (10) days after the date of submission.

(b) Approval by the District on items called for under these Specifications does not relieve the Contractor from the responsibility for errors, omissions or deviations from the Contract documents unless such deviations were specifically called to the attention of the Engineer in the letter of transmittal submitted with the material for approval.

(c) If the Contractor objects to any conditions imposed by the District in granting said approvals, he shall immediately give the District written notification.

27. Trench Shoring Plans.

(a) In compliance with Section 6705 of the Labor Code, the Contractor, at his sole expense, shall be required to submit detailed shoring plans for review by the District's Engineer for all construction projects and/or any related modifications, revision or changes thereto, which are in excess of \$25,000, for the excavation of any trench, trenches, or other excavation five (5) feet or more in depth.

(b) Shoring plans shall show the details of the shoring, bracing, sloping and all other provisions to be made for the workers' protection from the hazard of caving ground during the excavation of any trench, trenches, or other excavation.

(c) Such shoring plans shall be prepared by a qualified civil or structural engineer registered in the State of California in the event that such plans vary or deviate, in any manner, from the shoring system

standards as outlined in the State Construction Safety Orders issued by the Division of Industrial Safety, State of California.

(d) The Contractor shall submit the shoring plans to the Division of Industrial Safety, State of California, for its approval.

(e) The Contractor shall be required to submit the shoring plans within fifteen (15) days after notification of an award of a contract has been sent.

28. Safety Permit.

(a) In compliance with Section 6424 of the Labor Code, the Contractor, at his sole expense, shall be required to obtain a permit from the Division of Industrial Safety for the excavation of any trench, trenches, or other excavation five (5) feet or more in depth, prior to beginning any excavation work that is not covered by Section 6422 of the Labor Code.

(b) A copy of all permits issued and the related construction safety orders approved by the Division of Industrial Safety shall be filed with the District within fifteen (15) days after notification of the award of a contract, or within three (3) days after issuance of the permit, and prior to the beginning of the excavation of any trench, trenches, or other excavation five (5) feet or more in depth.

(c) Additional permits may be required for each modification, revision or change in the work.

(d) Safety permits required by Section 6424 of the Labor Code shall be in addition to all other permits required.

29. Personal Attention. The Contractor shall give his personal attention constantly to the faithful prosecution of the work, and shall be present, either in person or by a duly authorized and competent representative, on the site of the work continually during its progress, to receive directions or instructions from the Engineer. Whenever the Contractor is not present on any part of the work where it may be desired to give directions, orders may be given by the Engineer, and shall be received and obeyed by the superintendent or foreman who may have charge of the particular part of the work in reference to which orders are given.

30. Laws, Regulations and Permits.

(a) The contractor shall give all notices required by law and comply with all laws, ordinances, rules and regulations pertaining to the conduct of the work. The contractor shall be liable for all violations of the law in connection with the work furnished by the contractor. If the contractor observes that the drawings or specifications are at variance with any law or ordinance, rule or regulation, he shall promptly notify the engineer in writing and any necessary changes shall be made by written instruction or change order. If the contractor performs any work knowing it to be contrary to such laws, ordinances, rules and regulations and without giving notice to the engineer, the contractor shall bear all costs arising therefrom.

(b) The Contractor shall submit a certification that they are in compliance with the Civil Rights Act of 1964 as amended by the Equal Employment Opportunity Act of 1972, the California Fair Employment Practice Act of 1959, as amended, California Labor Code Section 1777.5 and Section 1735 and any other applicable Federal and State laws and regulations hereinafter enacted. Certification of

Compliance with Executive Order 11246, as amended, will be required when applicable. Such certification shall be on forms satisfactory to the District.

- (c) The following are exempted from the above provisions in relation to affirmative action efforts:
- (1) Contractors, subcontractors and suppliers who have a paid work force of less than fifteen (15) persons.
 - (2) Contracts and subcontracts which do not exceed \$10,000.00.
 - (3) Contracts and subcontracts which are deemed by the Board to be an "Emergency" nature or an apparent "Sole Source" purchase.
 - (4) Exemptions may be denied by the Board pursuant to a finding by the District that the exemption is having an adverse effect on the purpose of these Specifications. Additional exemptions may be granted by the Board for reasons of a similar finding.

(d) The Contractor shall only use equipment that complies with the state air quality regulations and the Ventura Air Pollution Control District regulations.

31. Sales and/or Use Taxes. Except as may be otherwise specifically provided herein, all sales and/or use taxes assessed by Federal, State or local authorities on materials used or furnished by the Contractor in performing the work hereunder shall be paid by the Contractor.

32. Construction Schedule. Prior to commencing the work, the Contractor shall submit a detailed construction schedule. At the beginning of each month as may be required by the Engineer, the Contractor shall submit an updated construction schedule. Said construction schedule shall show the order in which the Contractor proposes to complete the work, the dates when the various parts of the work are to begin and the estimated dates of completion. The detailed schedule shall be a modified bar type and shall show each principal item of work or activity.

33. Inspection.

(a) All materials furnished and all work done under these Specifications shall be subject to rigid inspection. The Contractor shall furnish the Engineer every reasonable facility for ascertaining whether the work is in accordance with the requirements and intent of these Specifications.

(b) Work done in the absence of prescribed inspection may be required to be removed and replaced under the proper inspection. The entire cost of removal and replacement, including the cost of all materials which may be furnished by the District and used in the work removed, shall be borne by the Contractor, irrespective of whether the work removed is found to be defective.

(c) Work covered up without the authority of the Engineer shall, upon order of the Engineer, be uncovered to the extent required, and the Contractor shall bear the entire cost of performing all the work and furnishing all the materials necessary for the removal of the covering and its subsequent replacement, as directed and approved by the Engineer.

(d) Nothing in these Specifications shall be construed to mean that the District will provide continuous inspection. The Contractor shall cooperate and coordinate his activities in order that he work can be inspected to the satisfaction of the Engineer.

(e) The Contractor shall keep the Engineer informed, a reasonable time in advance, of the times and places at which he intends to do work, so that the inspection and the necessary measurements may be made with a minimum of inconvenience to the Engineer, or delay to the Contractor.

34. Construction Staking.

(a) The Engineer will provide only minimal construction staking, the extent of which will be described in the Special Conditions hereof. The Contractor shall be required to provide all other additional staking and/or measurements necessary for the proper execution of the work.

(b) The Contractor shall notify the Engineer in writing at least five (5) working days before the time the Contractor will require the construction staking.

(c) The Contractor shall be required to preserve all bench marks, monuments, survey marks and construction stakes, and in case of their removal or destruction caused by the Contractor's activities, the Contractor shall be liable of the cost of their replacement.

35. Construction Interferences.

(a) Insofar as practicable during the progress of the work, the Contractor shall not disturb, but shall support and protect against injury, and maintain in good operating condition at his own expense, all subsurface, surface and overhead utilities, structures and other facilities as are encountered in the prosecution of the work.

(b) In the event that subsurface, surface, or overhead utilities, structures or other facilities are required to be disturbed or removed out permit the construction of the work, the Contractor shall not do any work that would affect such utilities, structures or facilities, or enter upon the right of way or other lands appurtenant thereto until notified by the Engineer that authority has been obtained to do so. The Engineer will make all necessary arrangements with the owner or other utilities for their relocation and reconnection, without cost to the Contractor, including the reconnection of services and the resurfacing of trenches required for said location; provided such arrangements shall not relieve the Contractor of his responsibilities as outlined in Section 2(b) of these General Conditions, nor the responsibility of proper care and protection of any utilities, structures or facilities encountered because of such varying conditions. The Contractor shall coordinate his operations with those of the owner or owners concerned with the disturbance or removal of facilities to minimize the inconvenience imposed on all affected parties.

(c) Except as provided in Section 4215 of the Government Code and in the event the Contractor disturbs, disconnects or damages any subsurface, surface, or overhead utility, structure or other facility prior to the making of necessary arrangements by the Engineer with the owner thereof, he shall immediately give to the owner notice of said disturbance, disconnection, or damage, and the Contractor shall assume all responsibility connected therewith, event in the even such damage occurs after backfilling or is not discovered until after completion of backfilling, and the provisions of this subsection shall continue in force until the termination of the guarantee period provided.

(d) All facilities removed shall be reconstructed as promptly as is possible in its original or other authorized location, and in a condition at least as good as when removed and subject to the inspection of the owner or of the governing body having jurisdiction.

(e) During the performance of the work under these Specifications, the owners or agencies in control of any of the facilities affected by the work shall have the right to enter, when necessary, upon the project right of way, or upon any street or other public way affected by the Contractor's operations, or any portion thereof, for the purpose of maintaining service and of making changes in or repairs to said facilities.

(f) The District reserves the right during the progress of the work and upon determination of the actual position of the existing utilities, structures, and other facilities, to make changes in the grade or alignment, or both, of the District's facilities wherever by so doing the necessity for relocation as provided herein of such utility, structures, or other facility will be avoided; provided that such changes shall not entitle the Contractor to additional compensation other than according to the prices named in the Bidding Sheet for the respective contract items.

(g) In the event the Contractor discovers a substructure as defined in Section 4215 of the Government Code and not identified by the District on the contract plans and Specifications, the Contractor shall be required to notify the District in writing. In the event that such discovery may cause extra work, the Contractor shall be required to obtain written authorization to change or modify the work according to Sections 14 and 18 of these General Conditions of the Specifications.

(h) Whether the Contractor is entitled to any additional compensation for any work hereinbefore described in Section 36 of these General Conditions shall be governed by the applicable portions of Section 4215 of the Government Code or amendments thereto.

(i) The Contractor shall make every effort to protect and preserve all trees encountered in the work. Any trees which unreasonably interfere with the work shall, with the approval of the Engineer, be removed by the Contractor. The cost of the removal shall be borne by the Contractor.

36. Materials, Workmanship, and Tests. The Contractor shall submit samples, specimens, or test pieces of such materials to be furnished or used in the work as the Engineer shall require. All materials must be new and must be of the specified quality and equal to approved samples. The Contractor shall furnish, without cost to the District, such quantities of construction materials as may be required for test purposes, and shall place at the Engineer's disposal all available facilities for and cooperate with him in the sampling and testing of all materials and workmanship. All work shall be done and completed in a thorough workmanlike manner, notwithstanding any omission from these Specifications or the Drawings.

37. Certification of Materials and Equipment

(a) All materials and equipment furnished by the Contractor shall be according to these Specifications. Any time when requested by the Engineer, the Contractor shall furnish written certification from the manufacturer of the various materials and equipment that such materials and equipment do meet all of the requirements of these Specifications. When requested by the Engineer, such certification shall be furnished to the District before payment to the Contractor, for the material and/or equipment in question, will be made.

(b) Where reference is made in these Specifications to a specification or test designation of the American Water Works Association, the American Society for Testing and Materials, the American Association of State Highway Officials, Federal Specifications, or any other recognized national organization, and the number or other identification accompanying the test designation representing the year of adoption of latest revision of the test is omitted, it shall mean the test method in effect on the date of the Notice Inviting Bids for the work.

38. Defective Work or Materials.

(a) The inspection of the work shall not relieve the Contractor of any of his obligations to fulfill his contract as herein prescribed, and defective work shall be made good, and unsuitable materials may be rejected, notwithstanding that such work and materials have been previously inspected by the Engineer and accepted or estimated for payment. If the work, or any part thereof, shall be found defective at any time before the final acceptance of the whole work, the Contractor shall forthwith make good such defect without compensation in a manner satisfactory to the Engineer and shall be charged for any excess material furnished by the District.

(b) If any materials furnished and brought upon the ground by the Contractor for use in the work, or selected for the same by him, shall be condemned by the Engineer as unsuitable or not in conformity with the Specifications, the Contractor shall forthwith discard such materials and remove them to a satisfactory distance from the vicinity of the work.

(c) If the Contractor shall fail or neglect to make ordered repairs of defective work or to remove condemned materials from the work within ten (10) days after the service by the Engineer of an order to do so, the Engineer acting on behalf of the District may make the ordered repairs or remove the condemned materials and deduct the cost thereof from any monies due the Contractor.

39. Use of "Or Equal."

(a) Any material or article of equipment designated by manufacturer's name, trade name, catalog reference or brand and qualified by "or equal" shall be understood to be a standard of quality and performance. Articles of other make will be acceptable provided they are, in the opinion of the Engineer, of equal quality and/or capable of equal performance. Names, brands and characteristics of proposed substitute materials shall be submitted to the Engineer for approval and no such substitute materials shall be purchased or delivered to the project until the Engineer's approval, in writing, has been obtained.

(b) The Contractor may be required to obtain certification from a qualified testing laboratory approved by the Engineer that such proposed substitute materials meet the minimum requirements in the Specifications, and/or that such proposed substitute materials are of equal quality and performance of the material or article designated in the Specifications. Such certification shall be required prior to obtaining the Engineer's approval, and shall be at the sole expense of the Contractor.

40. Property Rights in Materials.

(a) Nothing in this contract shall be construed as vesting in the Contractor any right of property in the materials used after they have been attached or affixed to the work or the soil, or after payment has been made for the value of unused material delivered to the site of the work as provided for in Sections 45, 58 through 65 inclusive hereof. All such materials attached or affixed or unused shall become the property of the District.

(b) The District reserves the right to use any or all of the completed facilities either after said facilities are connected to the existing facilities or otherwise completed by the Contractor as set forth in Section 45 hereof and prior to acceptance of the work by the Board.

41. Title to Materials Found on the Work. Except as may otherwise be provided in these Specifications, the right to the use of all soil, stone, gravel, sand and all other materials and equipment developed or obtained in the excavation or other operations by the Contractor or any subcontractor or any of their employees, and the right to use and/or dispose of the same, are hereby expressly reserved by the District and neither the Contractor nor any subcontractor, nor any of their employees shall have any right, title or interest in or to any part thereof nor shall they, nor any of them, assert or make any claim thereto. The Contractor shall be permitted to use in the work without charge any such materials which meet the requirements of these Specifications.

42. Patents and Copyrights. The Contractor shall hold and save the District, its officers, agents and employees, harmless from liability of any nature and kind, including costs and expense, for or because of any copyrighted or uncopyrighted composition, secret process, patented or unpatented invention, article, or appliances, manufactured, furnished, or used by him in the performance of this contract, including their use by the District, unless otherwise specifically stipulated in this contract.

43. Responsibility for Safe Storage. The Contractor shall be responsible for the safe storage of the material furnished by or to him and accepted by him and intended for the work until it has been incorporated in the completed project. The interior of all pipe, fittings and other accessories shall be kept free from dirt and foreign matter at all times.

44. Completion. When in the opinion of the Contractor, the work under this contract has been fully completed according to the plans and Specifications, he shall notify the Engineer. Upon such notification, the Engineer shall, within a reasonable time, make a field inspection of the work and shall satisfy himself by examination and such tests as may be necessary that the work has been fully and properly completed according to the plans and Specifications. If any deficiencies are found, the Engineer shall notify the Contractor of the measures to be taken to correct them. When all deficiencies, if any, are corrected to the satisfaction of the Engineer, the work shall be deemed completed and the date of such completion shall be used in computing the Liquidated Damages, if any, as set forth in Section 24.

45. Final Cleanup. Upon completion of the work and before the final inspection and estimate is prepared, the Contractor shall, at his own expense, dispose of and remove from the vicinity of the work, all rubbish, unused materials and other items used under his direction during construction and perform cleanup to the satisfaction of the Engineer.

46. Responsibility for a Safe Place to Work.

(a) The Contractor's attention is directed to Section 4 of these General Conditions entitled, "Indemnification of District."

(b) The Contractor shall be responsible for the maintenance of a safe place to work and any safety in or about the work site. The Contractor shall be required to conform to all of the applicable Construction Safety Orders issued by the Division of Industrial Safety of the State of California.

(c) The contractor shall execute and maintain his work so as to avoid injury or damage to any person or property. The contractor shall comply with the requirements of the specifications relating to safety measures applicable in particular operations or kinds of work.

(d) In carrying out his work, the contractor shall at all times, exercise all necessary precautions for the safety of employees appropriate to the nature of the work and the conditions under which the work is to be performed, and be in compliance with all federal, state and local statutory and regulatory requirements including State of California, Division of Industrial Safety (Cal/OSHA) regulations. Safety precautions as applicable shall include, but not be limited to, adequate life protection, and life saving equipment; adequate illumination for underground and night operations; instructions in accident prevention for all employees such as machinery guards, safe walkways, scaffolds, ladders, bridges, gang planks, confined space procedures, trenching and shoring, and other safety devices, equipment and wearing apparel as are necessary or lawfully required to prevent accidents or injuries; and adequate facilities for the proper inspection and maintenance of all safety measures.

(e) The names and telephone numbers of at least two medical doctors practicing in the vicinity and the telephone number of the local emergency response services shall be prominently displayed adjacent to telephones at the project site.

47. Public Convenience and Safety.

(a) The Contractor shall provide for the protection of the traveling public. The Contractor shall be required to furnish and maintain safety devices and other measures required for the public safety, which devices and measures shall conform to the requirements of Section 21406 of the Vehicle Code, any sign manual and current standard specifications of the Division of Highways. The Contractor shall conduct his operation to avoid unnecessary interference with the flow of traffic along highways, streets, roads, etc., used for vehicular traffic. Where any highway, street, road, etc., used for vehicular traffic is required to be kept open, the Contractor shall be required to furnish and maintain warning signs, lights, barricades, flagmen and other safety devices and measures necessary to provide adequate protection of the traveling public. Such protection shall be at the sole expense of the Contractor. Any highway, street maintenance or repair work required by local authorities concerning necessary operation under this contract shall be performed by the Contractor at his sole expense.

(b) Vehicular access to any driveway shall be maintained to the property line unless necessary construction precludes such access for reasonable periods of time.

(c) Vehicular and pedestrian access to any fire hydrant shall be maintained at all times during the construction of the work.

48. Safety, Sanitary and Medical Requirements.

(a) The Contractor, his employees and the subcontractors, if any, and their employees shall promptly and fully carry out the existing safety, sanitary and medical requirements as may from time to time be prescribed by the District to the end that proper work shall be conserved and safeguarded. In case such regulations and orders are not observed by the Contractor, they may be enforced by the Engineer at the Contractor's expense.

(b) Contractor shall notify District in writing within twenty-four (24) hours should an employee, officer or agent of Contractor or subcontractor incur personal injury while present on District properties or employed by District. District shall be furnished copies of all medical reports or accident reports filed or required by any local state or federal agency or regulatory body.

49. Character of Workers.

(a) None but skilled workers shall be employed on work requiring special qualifications. All equipment operators, pipelayers and jointers shall be well qualified and experienced in their work. All welding, however minor, shall be done by competent, certified welders, who have been qualified under Section IX of the ASME Boiler and Pressure Vessel Code, API Publication 1104 or such other standard as may be satisfactory to the Engineer. The Engineer shall have the right any time to call for and witness the making of test specimens by any welding operator according to these standards, and the expense of such tests shall be borne by the Contractor. When required in writing by the Engineer, the Contractor, or any subcontractor shall discharge any person who is, in the opinion of the Engineer, incompetent, unfaithful, disorderly or otherwise unsatisfactory, and shall not again employ such discharged person on the work except with the consent of the Engineer. Such discharge shall not be the basis of any claim for compensation or damages against the District or any of its officers.

(b) Enforcement of Order. The Contractor shall be responsible for maintaining good order at the site where work is performed under this contract and to that end shall employ such watchmen or other persons as may be required. Unauthorized persons shall be excluded from the site of the work. The Contractor shall not sell, nor shall he permit or suffer the introduction or use of, intoxicating liquors or narcotics upon the work embraced in these Specifications or upon any of the grounds occupied or controlled by him in connection with such works.

50. Subcontracts.

(a) Subcontracts will be permitted subject to the following provisions. No subcontract will be permitted which has the effect of avoiding the residence or wage requirements or any other provisions of the main contract. Individual subcontractors or members of contracting or subcontracting organizations personally engaged upon the work shall be subject to all the requirements of these specifications applicable to employees working for wages, including but not limited to, wages, hours of work, character of workers and certified payrolls.

(b) Reference is hereby made to the provisions of the Subletting and Subcontracting Fair Practices Act, Public Contract Code Section 4100, commencing with Section 4100, also known as the "Subletting and Subcontracting Fair Practices Act," which is incorporated herein and made a part hereof by reference, and the Contractor is bound thereby and shall be subject to the consequences named in Sections 4110 and 4111 of said Act in event of his violation thereof. Each bidder shall, in his bid or offer, set forth:

(1) The name and the location of the place of business of each subcontractor who will perform work or labor or render service to the Contractor in or about the construction of the work or improvement in an amount in excess of one-half of one percent of the Contractor's total bid or a subcontractor licensed by the State of California who, under subcontract to the prime contractor, specially fabricates and installs a portion of the work or improvement according to detailed drawings contained in the plans and specifications, in an amount in excess of one-half of one percent of the prime contractor's total bid; and (2) The portion of the work which will be done by each such subcontractor under said Act. The Contractor shall list only one subcontractor for each such portion as defined by the Contractor in his bid. If the Contractor fails to specify a subcontractor or if the Contractor specifies more than one subcontractor for the same one-half of one percent of the Contractor's total bid, the Contractor agrees that he is fully qualified to perform that portion himself, and that he shall perform that portion himself.

51. Access to the Site and Haul Routes.

(a) The Contractor shall make his own investigation of the condition of available public or private roads or other access, and of clearances, restrictions, bridge load limits, bond requirements, and other limitations that affect or may affect transportation and ingress and egress at the job site. The unavailability of transportation facilities or limitations thereon shall not become a basis for claims for damages or extension of time for completion of work. It shall be the Contractor's own responsibility to construct and maintain, at his own expense and at his own risk, any haul roads, access roads, bridges, or drainage structures required for construction operations.

(b) The use of existing roads (public or private) shall be at the Contractor's own expense and risk. It shall be the Contractor's responsibility to anticipate and meet all conditions properly imposed upon the use of existing roads by those having jurisdiction thereover, including (without limitation of the generality of the foregoing) seasonal or other limitations or restrictions, the payment of excess size and weight fees, and the posting of bonds conditioned upon repair of road damage caused by contract-generated traffic.

(c) The hauling of sand, gravel, asphalt or other intra job hauling, over public highways, roads or bridges, shall be in compliance with the applicable regulations and shall be such as to minimize interference with or congestion of local traffic.

(d) The cost of all work described in this paragraph shall be included in the prices bid in the schedule for other items of work.

52. Irregular Hours.

(a) When any work is to be performed at a time other than regular working hours Monday through Friday, the Engineer shall be given advance notice. In the event of Saturday and/or Sunday work, the approval of the Engineer shall be required before such work will be allowed. All costs for inspection attributed to irregular working hours shall be borne by the Contractor and shall be deducted from the contract amount. Irregular working hours shall be defined as follows, except for certain specialized jobs and circumstances:

- (1) Before 8:00 a.m. Monday through Friday.
- (2) After 4:30 p.m. Monday through Friday.
- (3) Anytime Saturday, Sunday, or District's Holidays.

(b) The Contractor will be exempt from this provision only for such work as required by the Specifications to be completed at other than working hours.

53. Eight-hour Law. In accordance with the provisions of Articles 1 and 3 of Chapter 1, Part 7, Division 2 of the Labor Code of the State of California eight (8) hours constitute a legal day's work. The Contractor shall forfeit, as a penalty to the District, \$25.00 for each worker employed in the execution of the contract by the Contractor or any subcontractor under him: for each calendar day during which such worker is required or permitted to work more than eight (8) hours in any one calendar day and forty (40) hours in any one calendar week in violation of the provisions of the Labor Code, and in particular, Sections 1810 to 1815 thereof, inclusive, except that work performed by employees of Contractor in excess of eight (8) hours per day and forty (40) hours during any one week shall be permitted upon compensation for all hours worked in excess of eight (8) hours per day at not less than one and one-half (1-1/2) times the basic rate of pay as provided in said Section 1815. The Contractor and each subcontractor shall keep accurate records showing the name of and schedule of hours worked by each worker employed by him concerning the contract. The records shall be kept open at all reasonable hours to inspection by the District and the Division of Labor Law Enforcement.

54. Payment of Wages. The issuance as payment for wages of any evidence of indebtedness is prohibited unless the same is negotiable and payable on demand without discount. Wages must be paid at least semi-monthly on regular pay days established in advance, and shall include all amounts for labor or services performed by employees of every description as required under the provisions of the California Labor Code.

55. Prevailing Rate of Per Diem Wages. Pursuant to the provisions of Articles 1 and 2 of Chapter 1, Part 7, Division 2 of the Labor Code of the State of California, not less than the general prevailing rate of per diem wages and not less than the general prevailing rate of per diem wages for legal holiday and overtime work for each craft or type of worker needed to execute the work contemplated under this contract, as determined by the District and as set forth in the schedule of such wages currently on file in the District office, shall be paid to all workers employed on such work by the Contractor or by any subcontractor doing or contracting to do any part of said work. The Contractor shall comply with Labor Code Section 1775. According to said Section 1775, the Contractor shall forfeit, as a penalty to the District, \$25 for each calendar day, or portion thereof, for each worker paid less than the stipulated prevailing rates for such work or craft in which such worker is employed for any work done under the contract by him or by any subcontractor under him in violation of the provisions of the Labor Code and in particular, Labor Code Sections 1770 to 1780, inclusive. In addition to said penalty and pursuant to said Section 1775, the difference between such stipulated prevailing wage rates and the amount paid to each worker for each calendar day or portion thereof for which each worker was paid less than the stipulated prevailing wage rate shall be paid to each worker by the Contractor. The Contractor and each subcontractor shall keep accurate records showing the name of and schedule of hours worked by each worker employed by him in connection with the contract. The records shall be kept open at all reasonable hours to inspection of the District and the Division of Labor Law Enforcement.

56. Unpaid Claims. If, upon or before the completion of the work herein agreed to be performed or at any time prior to the expiration of the period within which claims may be filed as prescribed by Section 3184 of the Civil Code, any person or persons shall bring against the District or against any agent or agents thereof any action to enforce such claim, the District shall, until the discharge thereof, withhold from the moneys under its control so much of said moneys due or to become due the Contractor under this contract

as shall be sufficient to satisfy and discharge the amount in such notice or under such action claimed to be due, together with the costs thereof; provided, that if the District shall in its discretion permit the Contractor to file such additional bond as is authorized by Section 3196 of the Civil Code, in a penal sum equal to one and one-fourth times the amount of said claim, said moneys shall not thereafter be withheld due to such claim.

57. Monthly Cost Estimates - Progress and Final Progress Payment.

(a) The Contractor shall submit, by the third calendar day of each month on a form acceptable to the District, his estimate of the amount and value of all acceptable work and any extra work or changes approved by the District, up to the last day of the preceding calendar month, for the District's approval; and the Contractor will request a progress payment for the work completed thereof.

(b) A deduction of five (5) percent shall be made from the total thus computed, and from the remainder there shall be further deducted any amounts due the District from the Contractor for supplies or materials furnished or services rendered and any other amounts that may be due the District under the terms of the contract. From the balance thus determined shall be deducted the amount of all previous payments and the remainder shall constitute the progress payment for that month. Such progress estimates shall not be required to be made by strict measurement, but they may be made by measurement or by estimation, or partly by one method and partly by the other, and it shall be sufficient if they are approximate only.

(c) Pursuant to Public Contract Code Section 22300, at the request and expense of the Contractor, securities equivalent to the amounts, if any, withheld by the District to ensure performance under this contract shall be deposited with the District. The District shall pay such moneys to the Contractor upon satisfactory completion of the contract. Securities eligible for investment under this section shall include those listed in Government Code Section 16430 or bank or savings and loan certificates of deposit. The Contractor shall be the beneficial owner of any securities substituted for moneys withheld and shall receive any interest thereon.

If the securities to be deposited by the Contractor pursuant to this provision are in registered form, the registration shall be transferred to the District.

(d) The Engineer shall approve the amount and value of all acceptable work and any extra work or changes approved by the District. Upon mutual agreement thereto, the Engineer will forward the approved estimate to the Administrative Services Manager for payment of the progress or final progress payment within ten (10) days thereafter.

(e) In the event that the Contractor and the District cannot mutually agree as to the amount and value of any item of work in the progress payment, the District will authorize payment of that portion of the progress and final progress payment to which the Contractor and the District have mutually agreed.

(f) The Contractor shall file with the District, within five (5) calendar days after the Engineer has issued written notice of the disputed items to the Contractor, a written statement setting forth in complete detail the basis for his disagreement, including, but not limited to, any amount or value in disagreement or dispute.

(g) Upon receipt of the Contractor's written statement, the General Manager shall investigate and consider the items of disagreement or dispute and render a decision thereon within a reasonable time, which decision shall be conclusive.

(h) In the event that the Contractor disagrees with the General Manager's decision, the Contractor's cost to the Contract for the delay in receiving the disputed balance of any progress or final progress payment, may be an item for arbitration according to Section 65 of the General Conditions.

(i) In the event the contract or any part thereof shall be suspended as provided in Section 21, the retained percentage as provided in Section 58(b) shall become the sole and absolute property of the District to the extent necessary to repay the District any excess in the cost of the work above the contract price. After issuance of notice to discontinue work, no payment upon progress estimates or otherwise shall thereafter be made to the Contractor for the work covered by said notice until completion of work and final settlement.

(j) The making of an estimate and payment in accordance therewith shall not preclude the District from demanding and recovering from the Contractor such damages as it may be entitled to under the contract because of his failure to comply with the Specifications.

58. Final Cost Statement.

(a) Final Cost Statement is a document which summarizes all of the Contractor's earnings under this contract and any amounts due the District from the Contractor, and from which the final payment is made.

(b) Upon completion of all of the work to be performed under this contract as set forth in Section 45, the Contractor shall submit for approval by the District in a form satisfactory to the District the amount and value of all acceptable work, and all extra work or changes approved by the District.

(c) The Engineer shall approve the amount and value of all acceptable work and any extra work or changes approved by the District. Upon mutual agreement thereof, this District will prepare the Final Cost Statement document which shall be submitted to the Contractor for his acceptance and signature.

(d) Upon endorsement by the Contractor of the Final Cost Statement, the District shall accept the work and authorize the final payment according to Sections 61 and 62 hereof.

59. Disputed Final Payment.

(a) In the event that the Contractor and the District cannot mutually agree as to the amount and value of the work, as set forth in this Final Cost Statement, the District will prepare the Final Cost Statement based upon the Engineer's determination of the amount and value of the work to which this Contractor may be entitled. Upon receipt of this Final Cost Statement, the Contractor shall file with the District within five (5) calendar days thereafter, a written statement setting forth in complete detail the basis for his disagreement, including, but not limited to, any amount or value in disagreement or dispute.

(b) The Board reserves the right to accept the work and file the necessary Notice of Completion.

(c) The Board shall investigate and consider the items of disagreement or dispute and render its decision thereon as to the amount due the Contractor within a reasonable time.

(d) The District will authorize payment of that portion of the Final Cost Statement to which the Contractor and the District have mutually agreed according to Section 58 hereof. Reference is made to Section 64 of these General Conditions.

60. Acceptance. Upon endorsement by the Contractor of the final cost statement, the Engineer shall prepare a memorandum of completion to advise the Board that the work has been satisfactorily completed and is ready for acceptance. At its next succeeding meeting, the Board shall consider acceptance of the work, and upon acceptance, shall authorize payment to the Contractor.

61. Final Payment.

(a) At the end of thirty-five (35) days after filing the notice of completion, as set forth above, the total balance due the Contractor, or in case of a dispute, any portion of the total balance which has been mutually agreed is not in dispute, if unencumbered, or any part thereof unencumbered, shall be paid provided that a guarantee bond shall have been filed with the District.

(b) For the purposes of this section, unencumbered balance means that portion over and above the face amount of all the stop notices on file with the District plus 25 percent of the face amount for potential interest and the cost of litigation as provided for in the Civil Code Section 3186-7.

62. Final Payment Terminates Liability.

(a) The acceptance by the Contractor of the final payment aforesaid shall be a release to the District and its agents from all claim liability to the Contractor for anything done related to the work or for any act or neglect of the District related to the work, except the claim against the District for the remainder, if any, of the amounts kept or retained as hereinbefore provided.

(b) No agent of the District shall be personally responsible for any liability arising under the contract. No claim shall be made or filed, and neither the District nor any of its agents shall be liable for, or held to pay any money, except as specifically provided in the contract.

63. Releases.

(a) Prior to payment of the final progress payment, the District may require the Contractor to obtain releases from each of the subs, material suppliers, equipment rental firms and employees, whether or not any have filed a preliminary notice with District, who have performed any work for the Contractor under this contract for which any payment may be warranted.

(b) Releases shall be submitted in a form approved by the District. Conditional releases may be unacceptable and acceptance thereof will be at the discretion of the District.

64. Disputes Settled by Arbitration. In the event there is a dispute between the parties as to any of the terms and conditions of this agreement, including but not limited to the accounting rendered by the District, and said dispute cannot be resolved according to Section 59 of these General Conditions, the dispute shall be submitted to arbitration before a single arbitrator agreed to by the parties or failing such agreement

appointed by the American Arbitration Association and resolved according to Article 1.5 of the Public Contract Code. Regardless of the manner of appointment of said arbitrator, the arbitration shall be conducted according to the then prevailing rules of the American Arbitration Association for commercial arbitration, except that each party shall bear their own costs and attorney's fees which they incur.

(a) As required under Section 20104, et seq., of the California Public Contract Code (Stats. of 1990), any demand of \$375,000 or less, by the Contractor for a time extension, payment of money, or damages arising from the work done by or on behalf of the Contractor pursuant to this Contract; or payment of an amount which is disputed by District shall be processed in accordance with the provisions of said Section 20104, et seq., related to informal conferences, non-binding judicially-supervised mediation, and judicial arbitration.

(b) A single written claim shall be filed under this Article prior to the date of final payment for all demands resulting out of the Contract.

(c) Within thirty (30) days of the receipt of the claim, District may request additional documentation supporting the claim or relating to defenses or claims District may have against the Contractor. If the amount of the claim is less than \$50,000, the Contractor shall respond to the request for additional information within fifteen (15) days after receipt of the request. The Contractor shall respond to the request within thirty (30) days of receipt if the amount of the claim exceeds \$50,000, but is less than \$375,000.

(d) Unless further documentation is requested, District shall respond to the claim within forty-five (45) days if the amount of the claim is less than \$50,000, or within sixty (60) days if the amount of the claim is more than \$50,000 but less than \$375,000. If further documentation is requested, District shall respond within the same amount of time taken by Contractor to respond, or fifteen (15) days, whichever is greater, after receipt of the information if the claim is less than \$50,000. If the claim is more than \$50,000 but less than \$375,000 and further documentation is requested by District, District shall respond within the same amount of time taken by the Contractor to respond or thirty (30) days, whichever is greater.

(e) If the Contractor disputes District's response, or District fails to respond, the Contractor may demand an informal conference to meet and confer for settlement of the issues in dispute. The demand shall be served on District within fifteen (15) days after the deadline of District to respond or within fifteen (15) days of District's response, whichever occurs first. District shall schedule the meet and confer conference within thirty (30) days of the request.

(f) If following the meet and confer conference the claim or any portion remains in dispute, the claimant may pursue the remedies authorized by law. For purposes of these provisions, the running of the period of time within which a claim must be filed shall be tolled from the time the claimant submits his or her written claim until the time the claim is denied, including any period of time utilized by the meet and confer conference.

END OF PART B

CASITAS MUNICIPAL WATER DISTRICT
SUMMARY OF INSURANCE, BOND & PAYMENT REQUIREMENTS
FOR VARIOUS CONSTRUCTION CONTRACTS

	Informal Under \$35,000	Formal \$35,000 & Over
<u>Certificates of Insurance</u> (CG 2010 Endorsement required))		
1. Workmen's Compensation	Yes	Yes
2. Commercial, General & Auto Liability	Yes	Yes
a. For one person per accident	\$1,000,000	\$1,000,000
b. More than one person per accident	\$1,000,000	\$1,000,000
3. Property damage per accident	\$1,000,000	\$1,000,000
4. Thirty days written notice prior to cancellation	Yes	Yes
<u>Bonds</u>		
Bidder's Bonds	None	10%
Payment Bonds (Material and Labor)* (Projects bid by CMWD only)	None	100%
Performance Bonds* (Projects bid by CMWD only)	None	100%
Maintenance and Guarantee Provisions	Yes	Yes
<u>Contracts</u>		
Period for Final payment upon acceptance	15 Days	35 Days
Amount of Retention	0, or stated in specs	5%
Progress Payment (if required, retain 5%)**	Per specs	Per specs
Final Cost Statement	None	Yes
Notice of Completion	None	Yes
Labor and Material Releases	Yes	Yes

* At the option of the District and depending upon the type of construction activity, payment bonds and/or performance bonds may be placed as a requirement on the job.

** If progress payments are required for a Purchase Order Contract, provisions therefor must be added.

NOTE:

The above listed are the minimum requirements for all construction contracts. Provisions are included within the Terms and Conditions for Purchase Order Contracts which will be issued for all jobs under \$35,000 and provisions should be included within the Specifications for all contracts which are \$35,000 and over. **The U.S. Bureau of Reclamation, Casitas Municipal Water District, their directors, officers, employees or authorized volunteers shall be named as additional insured as respects to all coverages listed above when the named insured is Lessee or Licensee of the Casitas Municipal Water District or when work is performed by the named insured for the Casitas Municipal Water District, and in both instances this coverage shall be primary.** Casitas, in addition to Certificates of Insurance, shall be provided with the ISO CG 2510 Endorsement or insurer's equivalent.

In accordance with the provisions of Section 1770 of the California Labor Code, the District has ascertained the general prevailing rates of wages applicable to the work to be done. It shall be mandatory upon the Contractor to whom the contract is awarded, and upon any subcontractor under him, to pay not less than the specified rates to all laborers and mechanics employed by him in the execution of the contract. The wage scale can be obtained from the California Labor Relations Board website at:

<http://www.dir.ca.gov/dlsr/DPreWageDetermination.htm>.